

JVC

SERVICE MANUAL

HD MEMORY CARD CAMERA RECORDER

GY-HM790U, GY-HM790CHU, GY-HM790E, GY-HM790CHE

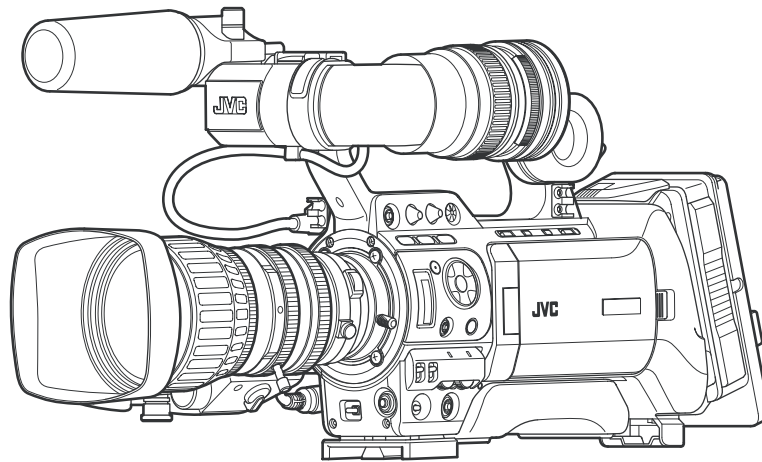

* The illustration shows the GY-HM790E with the supplied viewfinder, microphone and lens attached.

* GY-HM790CHU/GY-HM790CHE does not come with a lens.

Note :

Lead free solder used in the board (material : Sn, Ag, In, Bi, melting point : 227 Centigrade)

TABLE OF CONTENTS

1	PRECAUTION	1-3
1.1	SAFETY PRECAUTIONS	1-3
2	SPECIFIC SERVICE INSTRUCTIONS	1-5
3	DISASSEMBLY	1-5
3.1	GENERAL DESCRIPTION	1-5
3.2	HOW TO REMOVE THE EXTERIOR PARTS	1-5
3.3	HOW TO REMOVE THE OPTICAL BLOCK ASSEMBLY	1-7
3.4	HOW TO REMOVE THE MAJOR BOARDS	1-8
3.5	HOW TO REMOVE THE HANDLE ASSEMBLY	1-11
3.6	HOW TO REMOVE THE VIEW FINDER ASSEMBLY	1-12
4	ADJUSTMENT	1-14
4.1	FUNCTIONS REQUIRED FOR ADJUSTMENTS, SETUP	1-14
4.2	STANDARD SETUP	1-14
4.3	ADJUSTMENT MENU	1-15
4.4	FLOWCHART OF ADJUSTMENTS	1-17
4.5	CAMERA ADJUSTMENTS	1-18
5	TROUBLE SHOOTING	1-22
5.1	SERVICE MENUS	1-22
5.2	EEP-ROM	1-27
5.3	HOW TO UPDATE THE FIRMWARE	1-28
5.4	PRECAUTIONS WHEN CHANGING BOARDS	1-30

SPECIFICATION

	GY-HM790U	GY-HM790E	GY-HM790CHU	GY-HM790CHE
General				
Power	DC 12 V (10.5 V to 17 V)			
Power consumption	Approx. 26 W (During recording [when the camera recorder + standard lens + LCD monitor are in use])			
Mass	Approx. 3.7 k g	Approx. 3.9 k g	Approx. 2.7 k g	Approx. 2.8 k g
Allowable operating temperature	0 °C to 40 °C (32 °F to 104 °F)			
Allowable operating humidity	30 % RH			
Allowable storage temperature	-20 °C to 60 °C (-4 °F to 122 °F)			
Camera Section				
Image pickup device	1/3" Progressive IT CCD			
Color separation prism	F1.4, 3-color separation prism			
Sync system	Internal sync (built-in SSG)			
Lens mount	1/3" bayonet system			
Optical filter	OFF, 1/4, 1/16			
Gain	0dB, 3dB, 6dB, 9dB, 12dB, 15dB, 18dB, ALC			
Electronic shutter	1/6 to 1/10000, EEI			
Variable frame	10/30-60/30fps, 10/25-50/25fps, 10/24-60/24fps			
LCD monitor	4.3" LCD, 800 x 480 (WVGA, 410,000 pixels)			
Viewfinder	0.45" LCOS, 1.22 megapixels(852 x 480 x 3)			
Lens Section (GY-HM790U/GY-HM790E only)				
Lens	Canon F1.6, 14x, f = 4.4-61.6 mm (35 mm conversion: 32-448 mm)	-	-	-
Filter diameter	82 mm	-	-	-
Storage Section				
Supported media	SDHC (Class 6/10)			
Slots	x 2			
Time Code				
Time code signal	Compliant with SMPTE/EBU			
LTC input signal	1.0 Vp-p to 4.0 Vp-p, high impedance(unbalanced)			
LTC output signal	1.0 Vp-p to 4.0 Vp-p, low impedance (unbalanced)			
Terminal Section				
[Y/VIDEO], [PB], and [PR] analog video output terminals	Analog composite output (480i or 576i: Downconverted, 4: 3/16:9) :1.0 V (p-p), 75 Ω, BNC (unbalanced) Component output (720p/1080i) : Y: 1.0 V(p-p), 75Ω Pb, Pr: 0.7 V(p-p), 75 Ω, BNCx3 (unbalanced)			
[HD/SD-SDI] output terminal (480i or 576i : Downconverted / 720p /1080i: embedded audio), BNC (unbalanced)	HD-SDI:Compliant with SMPTE 292 M SD-SDI:Compliant with SMPTE 259 M			
[AUDIO INPUT 1/2] terminal	[MIC]:-60 dBu, 3k Ω , XLR (balanced),+48 V output (phantom power supply) [LINE]:+4 dBu, 10k Ω , XLR (balanced)			
[AUDIO OUTPUT] terminal	-8 ± 1 dBu (when audio signal process output is -20 dB), 1 k Ω, RCA x2(unbalanced)			
[PHONES] terminal	3.5 mm mini jack (stereo) x 2			
[REMOTE] terminal	6-pin JVC remote control connection			
[IEEE1394] terminal	4-pin			
[USB] terminal	Mini USB-B type, USB 2.0, miniB, slave function (mass storage class) only			
[GENLOCK INPUT] terminal	BB signal SMPTE 170M(RS-170A) NTSC/ITU-R BT.470-6 PAL HDTV 3 level synchronizing signal SMPTE 296 M/SMPTE 274 M BNC			
[AUX INPUT] terminal	Composite video signal 1.0 V (p-p), 75 Ω, BNC	-	Composite video signal 1.0 V (p-p), 75 Ω, BNC	-
[STUDIO] terminal	10 pin			
Video/Audio				
Recording time	Approx. 25 minutes (8 GB SDHC card, 35 Mbps, VBR mode)			
Video recording file format	QuickTime File Format (For Final Cut Pro) MP4 File Format (HD only) AVI File Format (SD only)			
	Video signal	HD (HQ mode):MPEG-2 Long GOP VBR, 35 Mbps (Max) MPEG-2 MP@HL HD (SP mode):MPEG-2 Long GOP CBR, 25 Mbps (1440x1080i)/19 Mbps (1280x720p) MPEG-2 MP@H14 SD:DV CBR, 25 Mbps (720x480i)/(720x576i)		
	Audio signal	LPCM 2ch, 48 kHz/16 Bit		
Video format	NTSC setting	HD (HQ mode):1920x1080/59.94i, 29.97p, 23.98p, 1440x1080/59.94i (MOV only), 1280x720/59.94p, 29.97p, 23.98p HD (SP mode):1440x1080/59.94i, 1280x720/59.94p, 29.97p, 23.98p		
		SD:720x480/59.94i	-	SD:720x480/59.94i
	PAL setting	HD (HQ mode):1920x1080/50i, 25p, 1440x1080/50i (MOV only), 1280x720/50p, 25p HD (SP mode):1440x1080/50i, 1280x720/50p, 25p		
	-	SD:720x576/50i	-	SD:720x576/50i
Accessories				
	Viewfinder, Microphone, Lens, Instructions, CD-ROM, Warranty Card	Viewfinder, Microphone, Lens, Instructions, CD-ROM	Viewfinder, Microphone, Instructions, CD-ROM, Warranty Card	Viewfinder, Microphone, Instructions, CD-ROM

SECTION 1 PRECAUTION

1.1 SAFETY PRECAUTIONS

Prior to shipment from the factory, JVC products are strictly inspected to conform with the recognized product safety and electrical codes of the countries in which they are to be sold. However, in order to maintain such compliance, it is equally important to implement the following precautions when a set is being serviced.

1.1.1 Precautions during Servicing

- (1) Locations requiring special caution are denoted by labels and inscriptions on the cabinet, chassis and certain parts of the product. When performing service, be sure to read and comply with these and other cautionary notices appearing in the operation and service manuals.
- (2) Parts identified by the Δ symbol and shaded (■) parts are critical for safety.
Replace only with specified part numbers.

NOTE :

Parts in this category also include those specified to comply with X-ray emission standards for products using cathode ray tubes and those specified for compliance with various regulations regarding spurious radiation emission.

- (3) Fuse replacement caution notice.
Caution for continued protection against fire hazard.
Replace only with same type and rated fuse(s) as specified.
- (4) Use specified internal wiring. Note especially:
 - Wires covered with PVC tubing
 - Double insulated wires
 - High voltage leads
- (5) Use specified insulating materials for hazardous live parts.
Note especially:
 - Insulation Tape
 - PVC tubing
 - Spacers
 - Insulation sheets for transistors
 - Barrier
- (6) When replacing AC primary side components (transformers, power cords, noise blocking capacitors, etc.) wrap ends of wires securely about the terminals before soldering.

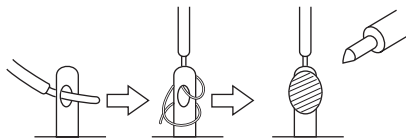

Fig.1-1-1

- (7) Observe that wires do not contact heat producing parts (heatsinks, oxide metal film resistors, fusible resistors, etc.)
- (8) Check that replaced wires do not contact sharp edged or pointed parts.
- (9) When a power cord has been replaced, check that 10-15 kg of force in any direction will not loosen it.

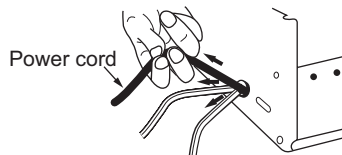

Fig.1-1-2

- (10) Also check areas surrounding repaired locations.
- (11) Products using cathode ray tubes (CRTs) In regard to such products, the cathode ray tubes themselves, the high voltage circuits, and related circuits are specified for compliance with recognized codes pertaining to X-ray emission. Consequently, when servicing these products, replace the

cathode ray tubes and other parts with only the specified parts. Under no circumstances attempt to modify these circuits. Unauthorized modification can increase the high voltage value and cause X-ray emission from the cathode ray tube.

- (12) Crimp type wire connector In such cases as when replacing the power transformer in sets where the connections between the power cord and power transformer primary lead wires are performed using crimp type connectors, if replacing the connectors is unavoidable, in order to prevent safety hazards, perform carefully and precisely according to the following steps.

- **Connector part number** :E03830-001
- **Required tool** : Connector crimping tool of the proper type which will not damage insulated parts.
- **Replacement procedure**

- a) Remove the old connector by cutting the wires at a point close to the connector. Important : Do not reuse a connector (discard it).

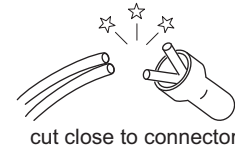

Fig.1-1-3

- b) Strip about 15 mm of the insulation from the ends of the wires. If the wires are stranded, twist the strands to avoid frayed conductors.

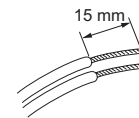

Fig.1-1-4

- c) Align the lengths of the wires to be connected. Insert the wires fully into the connector.

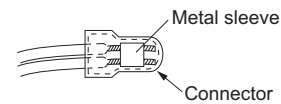

Fig.1-1-5

- d) As shown in Fig.1-1-6, use the crimping tool to crimp the metal sleeve at the center position. Be sure to crimp fully to the complete closure of the tool.



Fig.1-1-6

- e) Check the four points noted in Fig.1-1-7.

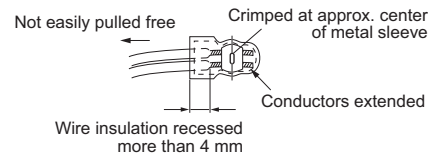

Fig.1-1-7

- (13) **Battery replacement caution notice.**
CAUTION RISK OF EXPLOSION IF BATTERY IS REPLACED BY AN INCORRECT TYPE.
DISPOSE OF USED BATTERIES ACCORDING TO THE INSTRUCTIONS.

1.1.2 Safety Check after Servicing

Examine the area surrounding the repaired location for damage or deterioration. Observe that screws, parts and wires have been returned to original positions. Afterwards, perform the following tests and confirm the specified values in order to verify compliance with safety standards.

(1) Insulation resistance test

Confirm the specified insulation resistance or greater between power cord plug prongs and externally exposed parts of the set (RF terminals, antenna terminals, video and audio input and output terminals, microphone jacks, ear-phone jacks, etc.). See table 1 below.

(2) Dielectric strength test

Confirm specified dielectric strength or greater between power cord plug prongs and exposed accessible parts of the set (RF terminals, antenna terminals, video and audio input and output terminals, microphone jacks, earphone jacks, etc.). See Fig.1-1-11 below.

(3) Clearance distance

When replacing primary circuit components, confirm specified clearance distance (d), (d') between soldered terminals, and between terminals and surrounding metallic parts. See Fig.1-1-11 below.

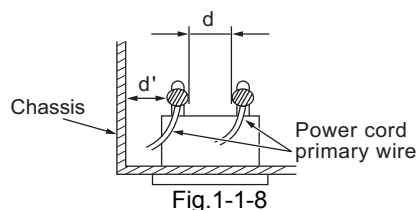

Fig.1-1-8

(4) Leakage current test

Confirm specified or lower leakage current between earth ground/power cord plug prongs and externally exposed accessible parts (RF terminals, antenna terminals, video and audio input and output terminals, microphone jacks, ear-phone jacks, etc.).

Measuring Method : (Power ON) Insert load Z between earth ground/power cord plug prongs and externally exposed accessible parts. Use an AC voltmeter to measure across both terminals of load Z. See Fig.1-1-9 and following Fig.1-1-12.

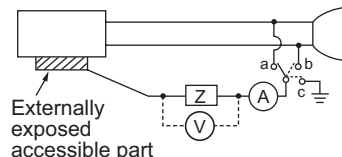
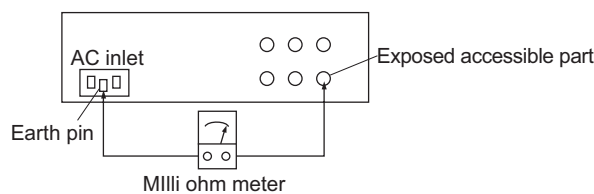

Fig.1-1-9

(5) Grounding (Class 1 model only)

Confirm specified or lower grounding impedance between earth pin in AC inlet and externally exposed accessible parts (Video in, Video out, Audio in, Audio out or Fixing screw etc.). Measuring Method:

Connect milli ohm meter between earth pin in AC inlet and exposed accessible parts. See Fig.1-1-10 and grounding specifications.



Grounding Specifications

Region	Grounding Impedance (Z)
USA & Canada	$Z \leq 0.1 \text{ ohm}$
Europe & Australia	$Z \leq 0.5 \text{ ohm}$

Fig.1-1-10

AC Line Voltage	Region	Insulation Resistance (R)	Dielectric Strength	Clearance Distance (d), (d')
100 V	Japan	$R \geq 1 \text{ M}\Omega/500 \text{ V DC}$	AC 1 kV 1 minute	$d, d' \geq 3 \text{ mm}$
100 to 240 V			AC 1.5 kV 1 minute	$d, d' \geq 4 \text{ mm}$
110 to 130 V	USA & Canada	$1 \text{ M}\Omega \leq R \leq 12 \text{ M}\Omega/500 \text{ V DC}$	AC 1 kV 1 minute	$d, d' \geq 3.2 \text{ mm}$
110 to 130 V 200 to 240 V	Europe & Australia	$R \geq 10 \text{ M}\Omega/500 \text{ V DC}$	AC 3 kV 1 minute (Class II) AC 1.5 kV 1 minute (Class I)	$d \geq 4 \text{ mm}$ $d' \geq 8 \text{ mm}$ (Power cord) $d' \geq 6 \text{ mm}$ (Primary wire)

Fig.1-1-11

AC Line Voltage	Region	Load Z	Leakage Current (i)	a, b, c
100 V	Japan	$1 \text{ k}\Omega$	$i \leq 1 \text{ mA rms}$	Exposed accessible parts
110 to 130 V	USA & Canada	$0.15 \mu\text{F}$ and $1.5 \text{ k}\Omega$	$i \leq 0.5 \text{ mA rms}$	Exposed accessible parts
110 to 130 V 220 to 240 V	Europe & Australia	$2 \text{ k}\Omega$	$i \leq 0.7 \text{ mA peak}$ $i \leq 2 \text{ mA dc}$	Antenna earth terminals
		$50 \text{ k}\Omega$	$i \leq 0.7 \text{ mA peak}$ $i \leq 2 \text{ mA dc}$	Other terminals

Fig.1-1-12

NOTE :

These tables are unofficial and for reference only. Be sure to confirm the precise values for your particular country and locality.

SECTION 2 SPECIFIC SERVICE INSTRUCTIONS

This service manual does not describe SPECIFIC SERVICE INSTRUCTIONS.

SECTION 3 DISASSEMBLY

About CH model : CH models are without only lens assembly.

3.1 GENERAL DESCRIPTION

3.1.1 Cautions

- (1) Always unplug the DC power or the battery before attaching, removing or soldering a part.
- (2) When unplugging a connector, do not pull the wire but grasp the connector body.
- (3) When attaching exterior cover, put the cables and wire in order and check carefully not to damage cables.

3.1.2 Screws used in camera components

The table shows the symbols, design, part numbers and colors of screws used with the camera components.

When disassembling or assembling the camera, be sure to install the correct screws by referring to the following table.

Symbol	Design	Part No.	Color
(S1)		QYSPSPU2040MA	Black
(S2)		QYSPSPU2080MA	Black
(S3)		QYSPSPU2030NA	Silver
(S4)		QYSPSPH4012NA	Silver
(S5)		QYSPSPU2080MA	Black
(S6)		QYSPSPU2040NA	Silver
(S7)		QYSDSP2605NA	Silver
(S8)		QYSDSP3008MA	Black
(S9)		LY30031-052A	Black
(S10)		QYSSSP2606NA	Silver
(S11)		QYSPSPU2060MA	Black
(S12)		QYSPSFU2040MA	Black
(S13)		QYSPSPH3008NA	Silver

3.2 HOW TO REMOVE THE EXTERIOR PARTS

3.2.1 Removing the left side cover assembly (See figure 1, figure 2, figure 3, figure 4, figure 5, figure 6 and figure 7)

- (1) Remove the two screws (S10) attaching the shoulder pad, then remove the shoulder pad.
- (2) Remove the one screw (S1) attaching the CN cover assembly.

NOTE :

- When attaching the shoulder pad, make sure to insert the guide rail of the shoulder pad into the hole of the bottom and tighten the screws.
- When attaching the shoulder pad, pressing the push plate and then slide the guide rail.

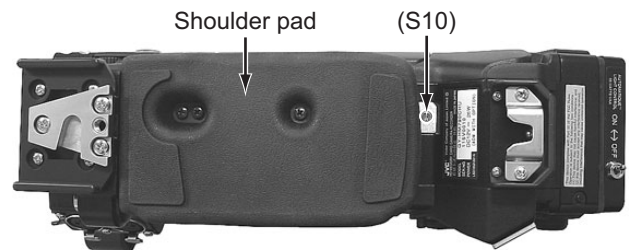

Fig.1

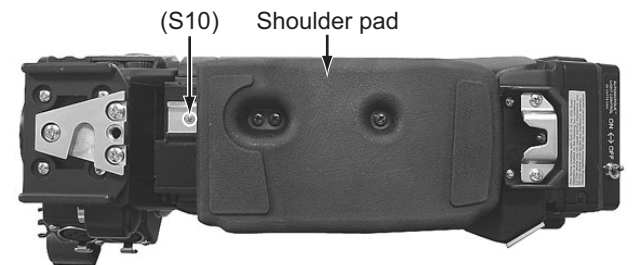

Fig.2

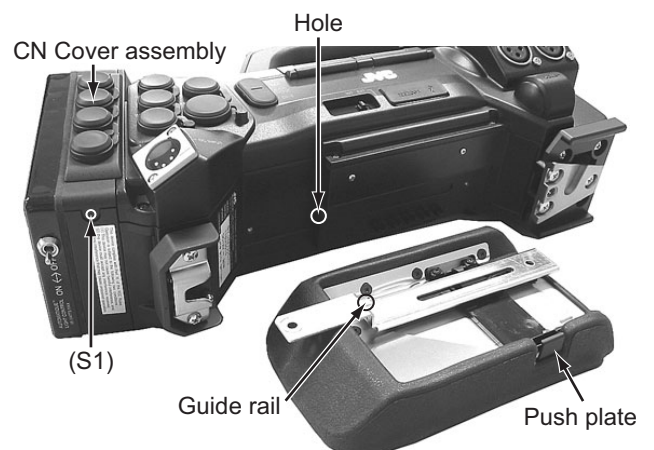

Fig.3

(3) Remove the two screws (S1), two screws (S11) and three screws (S2) attaching the left side cover assembly.

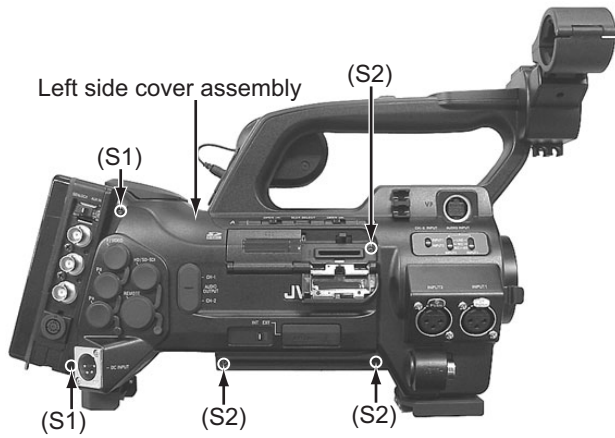

Fig.4



Fig.5

(4) Disconnect the wire from the connector CN84 on the BNC board.

(5) Disconnect the wire from the HD/SD terminal.

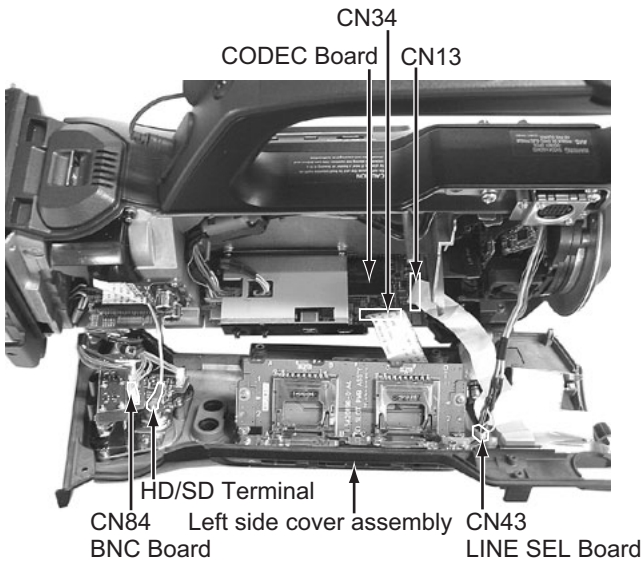

Fig.6

(6) Disconnect the wire from the connector CN93 on the ECAP board.



Fig.7

(7) Disconnect the wires from the connectors CN34 and CN13 on the CODEC board.

(8) Disconnect the wire from the connector CN43 on the LINE SEL board, then remove the left side cover assembly.

3.2.2 Removing the right side cover assembly (See figure 8, figure 9 and figure 10)

(1) Remove the five screws (S1) and two screws (S11) attaching the right side cover assembly.

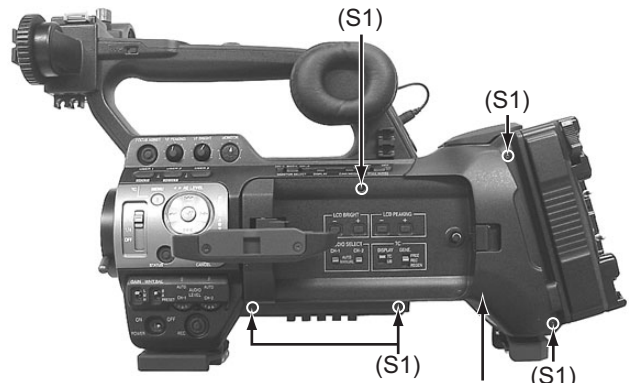
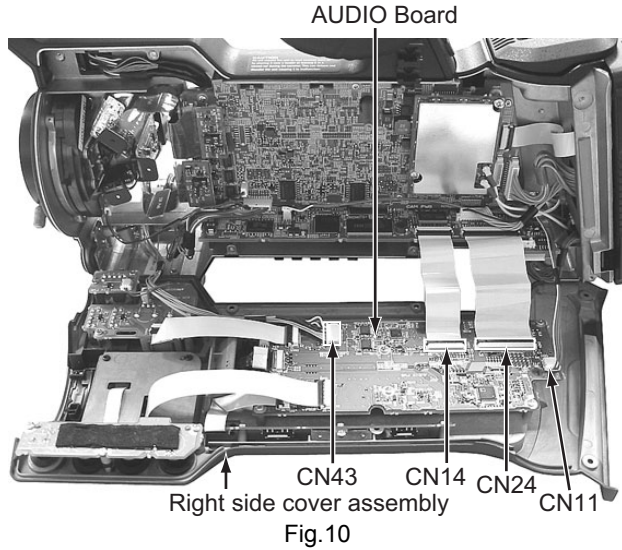

Fig.8



Fig.9

- (2) Disconnect the wires from the connectors [CN14](#), [CN24](#), [CN43](#) and [CN11](#) on the AUDIO board, then remove the right side cover assembly.



3.3 HOW TO REMOVE THE OPTICAL BLOCK ASSEMBLY (See figure 11, figure 12, figure 13 and figure 14)

CAUTION :

- When removing/mounting the optical block assembly in the camera, take care not to damage cables, also the positioning of the wire assembly is important. A malfunction may occur if wires are somehow caught up.
- Take also care not to press the IS boards or cables. If pressing strongly, the RGB registration of CCDs may be changed.

- (1) Remove the left side cover assembly and right side cover assembly (Refer to the 3.2)
- (2) Disconnect the FPC from the board to board connectors [CN26](#), [CN27](#) and [CN28](#) on the CAM board.
- (3) Disconnect the wire from the connector [CN90](#) on the CAM board.

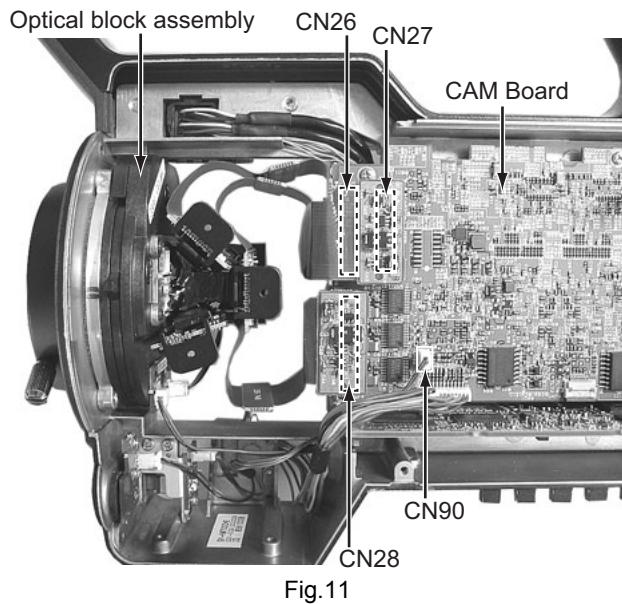

- (4) Remove the mount screw.

Note:

The glue has been applied to the mount screw.
Replace with new one when the mount screw was removed.

- (5) Remove the four screws (S8) attaching the optical block assembly, then remove the optical block assembly.

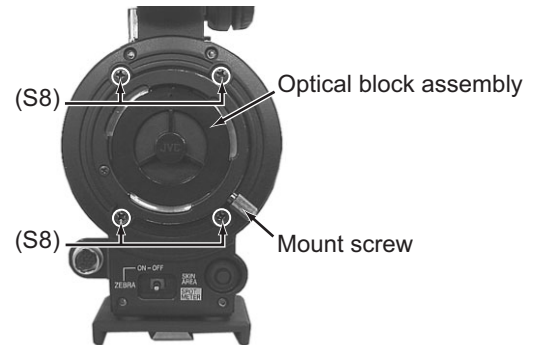

Fig.12

- (6) Remove the three screws (S12) attaching the fan motor and FNC board.

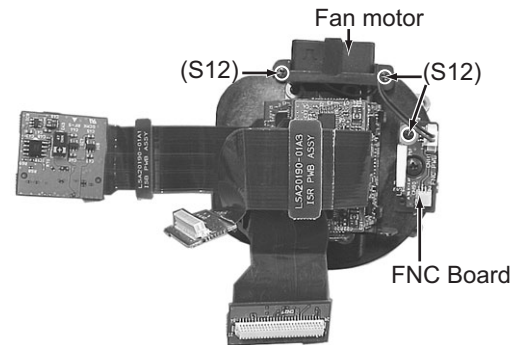

Fig.13

- (7) When replacing the optical block, be sure to attach the original fan motor and FNC board to new optical block, because those are not included on the optical block assembly.

Caution on handling the FAN MOTOR

To prevent abnormal sound of the FAN:

- Do not hold the FAN MOTOR shaft or the propeller as the FAN MOTOR has a precision structure. (The force of 0.3 N or over is NG.)
- Be careful not to give shock.
- Spread a cushion on the workbench. Do not lay down the FAN MOTOR on a hard board or a floor. (The FAN MOTOR dropped to the floor off the workbench is NG.)

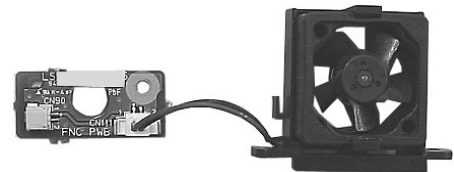

Fig.14

NOTE :

- The CCDs are bonded precisely to the prism by UV-curable adhesive. In case of trouble with a CCD, it is not possible to replace an individual CCD, but the entire optical block assembly should be replaced.
- The optical block assembly supplied as a service part.

3.4 HOW TO REMOVE THE MAJOR BOARDS

3.4.1 Removing the AUDIO board (See figure 15)

- (1) Remove the right side cover assembly (Refer to the 3.2.2)
- (2) Disconnect the wires from the connectors [CN10](#), [CN44](#), [CN45](#) and [CN62](#) on the AUDIO board.
- (3) Remove the six screws (**S3**) attaching the AUDIO board, then remove the AUDIO board.

NOTE :

CN62 may be slightly hard to connect FPC cable. Make sure to insert the cable to correct position.

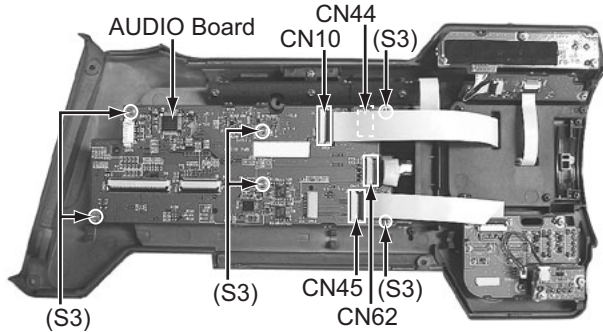

Fig.15

3.4.2 Removing the LCD monitor assembly (See figure 16 and figure 17)

- (1) Disconnect the FPC from the connector [CN62](#) on the AUDIO board.
- (2) Remove the two screws (**S12**) attaching the hinge unit cover, then remove the hinge unit cover.

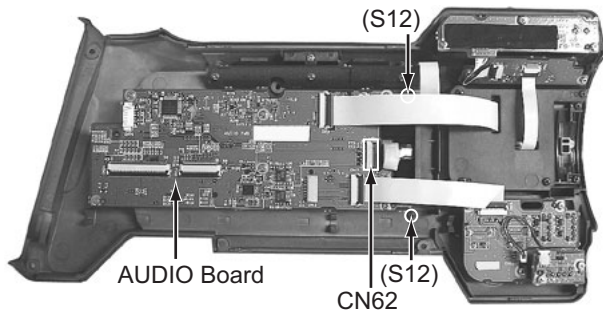

Fig.16

- (3) Remove the two screws (**S9**) attaching the hinge unit, then remove the LCD monitor assembly.

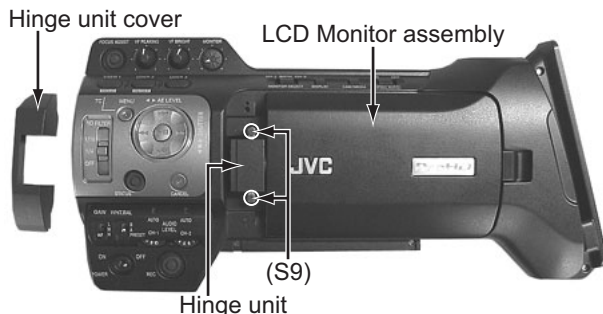

Fig.17

3.4.3 Removing the CAM board, SDI board and CODEC board (See figure 18, figure 19, figure 20, figure 21 and figure 22)

- (1) Remove the left side cover assembly and right side cover assembly (Refer to the 3.2)
- (2) Disconnect the wires from the connectors [CN26](#), [CN27](#), [CN28](#), [CN90](#), [CN8](#), [CN29](#) and [CN30](#) on the CAM board.
- (3) Remove the two screws (**S7**) attaching the SDI board, then remove the SDI board.
- (4) Remove the six screws (**S6**) attaching the CAM board.

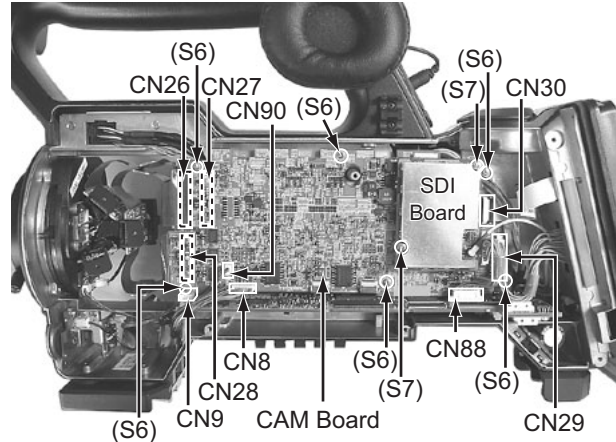

Fig.18

- (5) Disconnect the wires from the connectors [CN58](#), [CN57](#), [CN22](#), [CN67](#), [CN12](#), [CN88](#) and [CN9](#) on the CODEC board.

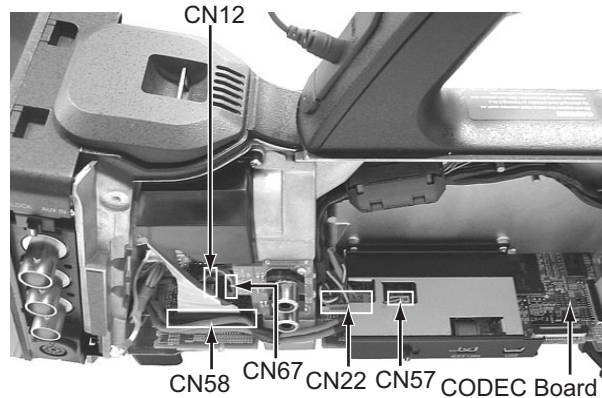

Fig.19

- (6) Remove the two screws (**S6**) attaching the CODEC board.

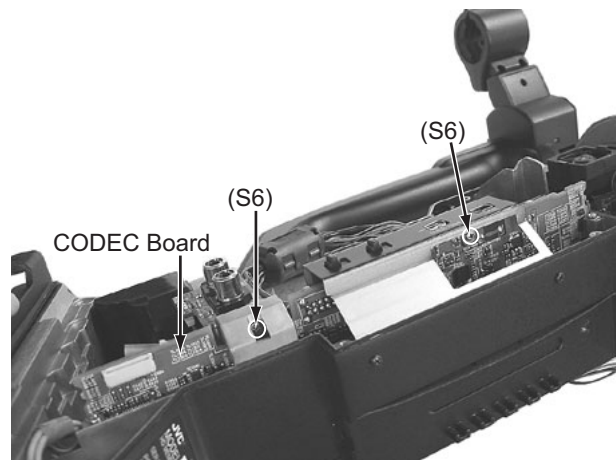

Fig.20

(7) To remove the CAM board and the CODEC board, slide the two boards together.

- As the CAM board and the CODEC board are connected board to board, be very careful when removing and attaching the boards.

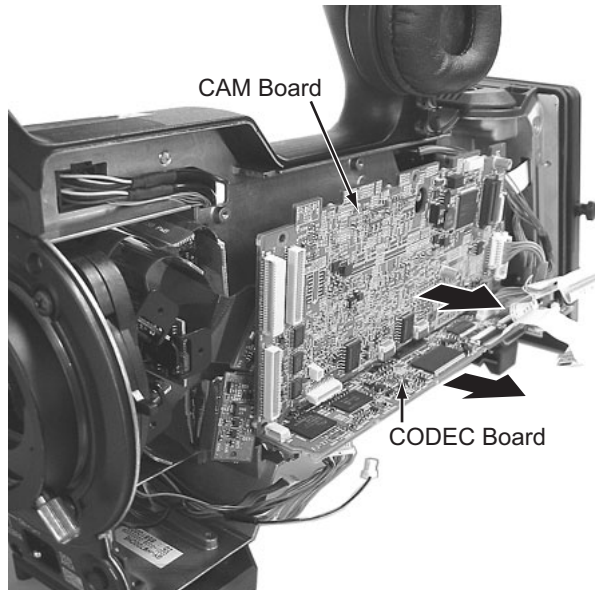

Fig.21

- When placing the removed CODEC board, be careful not to deform the connectors from [CN89](#) to [CN94](#) on the board.

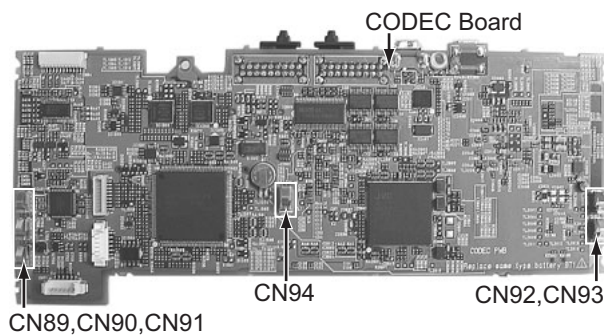
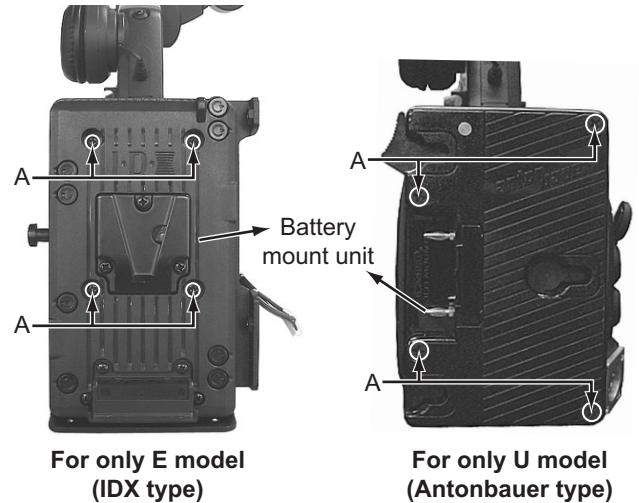

Fig.22

3.4.4 Removing the GENTC board and REG board (See figure 23, figure 24, figure 25, figure 26, figure 27, figure 28, figure 29, figure 30 and figure 31)

- Remove the right side cover assembly, and then disconnect the wires from the connector [CN88](#) on the CODEC board and [CN29](#) on the CAM board.
- Remove the four screws **A** attaching the battery mount unit.



For only E model (IDX type)

For only U model (Antonbauer type)

Fig.23

- Remove the four screws **B** attaching the bracket. (For only E model)

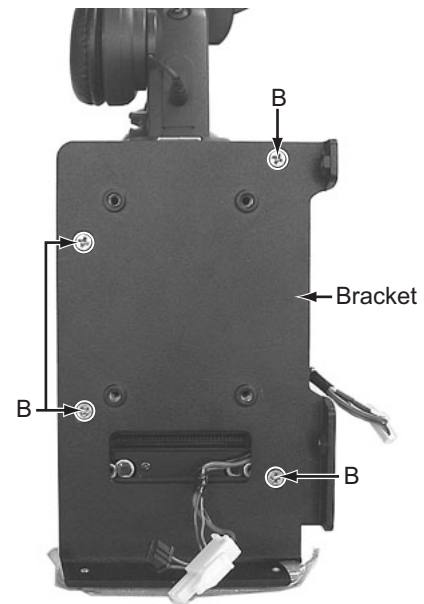
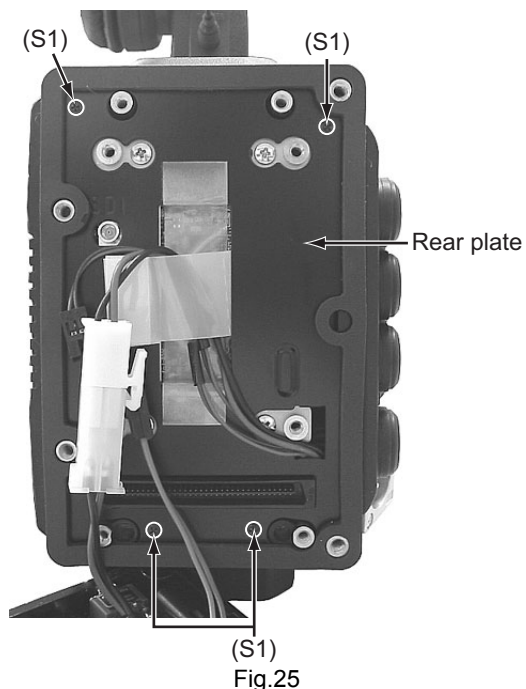
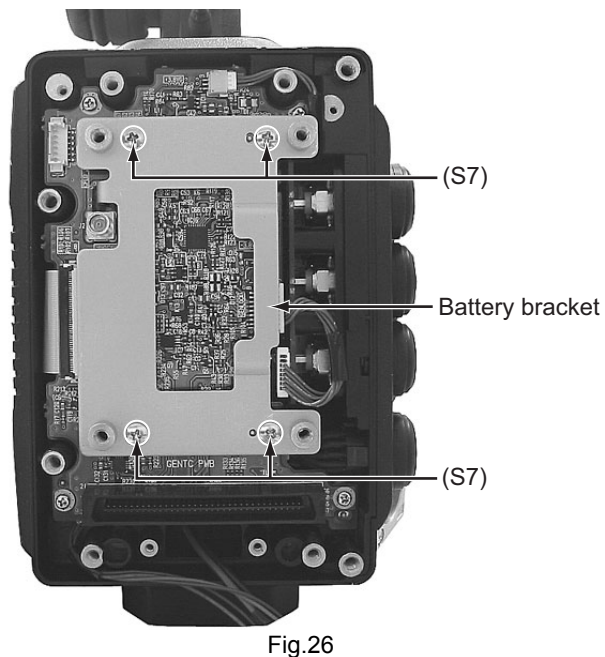

Fig.24

(4) Remove the four screws (S1) attaching the rear plate.



(5) Remove the four screws (S7) attaching the battery bracket.



(6) Remove the four screws (S6) attaching the GENTC board.

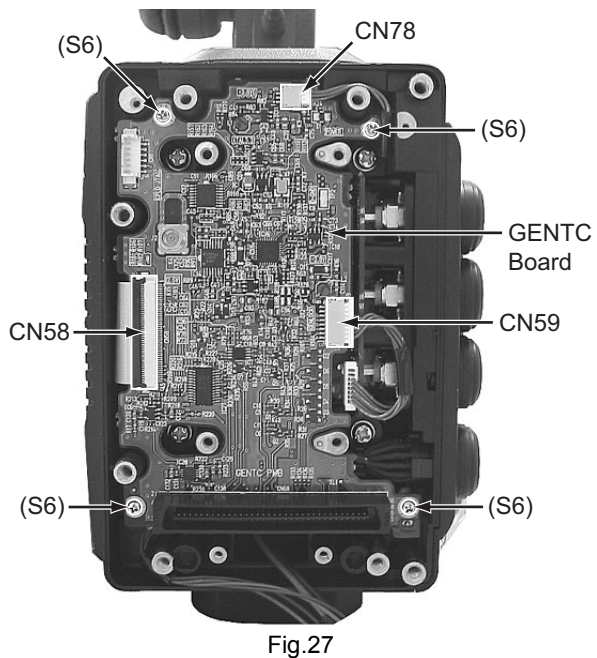

(7) Disconnect the wires from the connectors [CN58](#), [CN78](#), [CN59](#), [CN32](#), [CN67](#), [CN56](#), [CN92](#), [CN69](#), [CN57](#) and [J1](#) on the GENTC board.

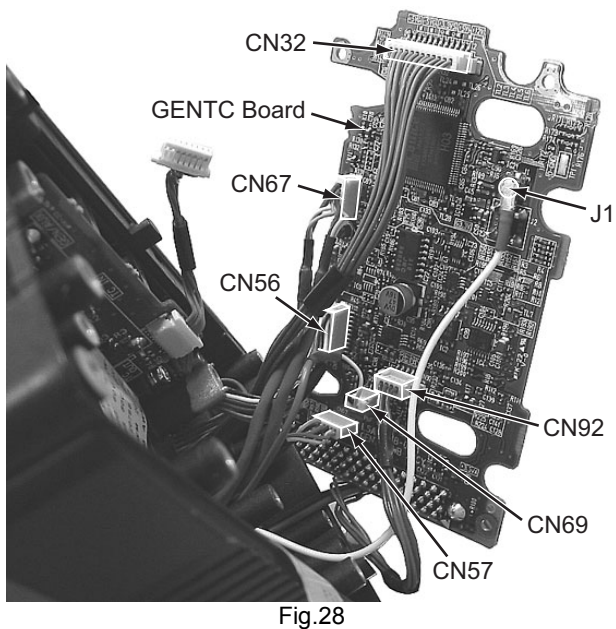

(8) Remove the four screws (S13) attaching the rear main base assembly.

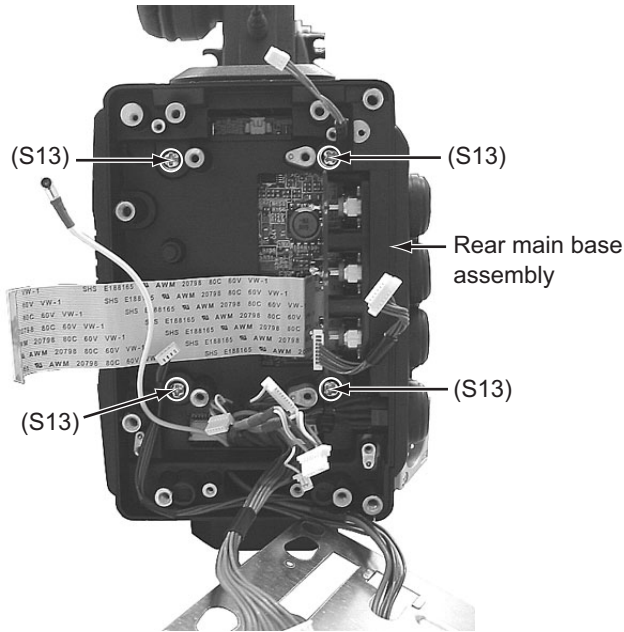

Fig.29

- (9) Remove the four screws (S6) attaching the REG board.
 (10) Disconnect the wires from the connectors [CN109](#), [CN30](#), [CN32](#), [CN91](#) and [CN31](#) on the REG board.

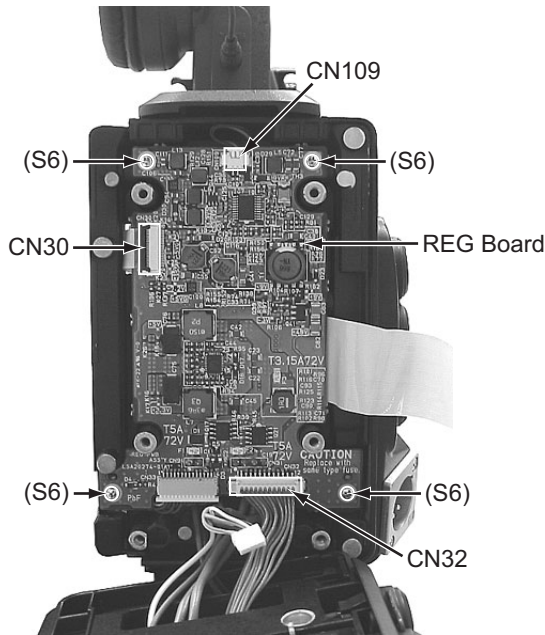

Fig.30

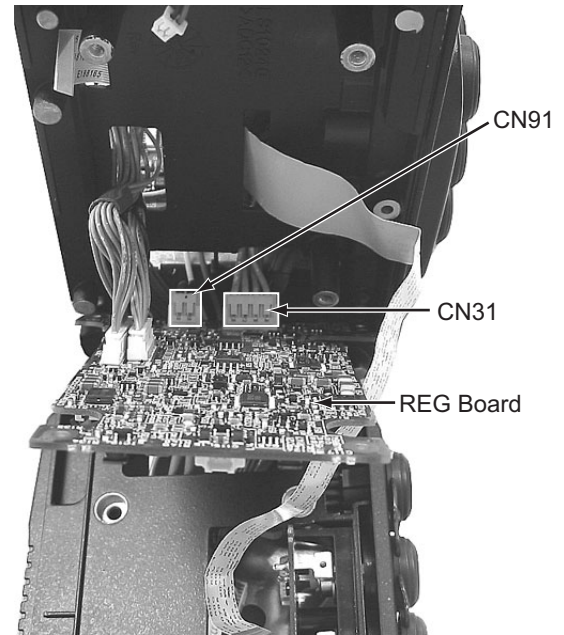

Fig.31

3.5 HOW TO REMOVE THE HANDLE ASSEMBLY (See figure 32, figure 33, figure 34 and figure 35)

- (1) Remove the left side cover assembly and right side cover assembly (Refer to the 3.2)
- (2) Remove the two screws (S5) attaching the handle cover T.
- (3) Remove the one screw (S1) attaching the handle cover R.

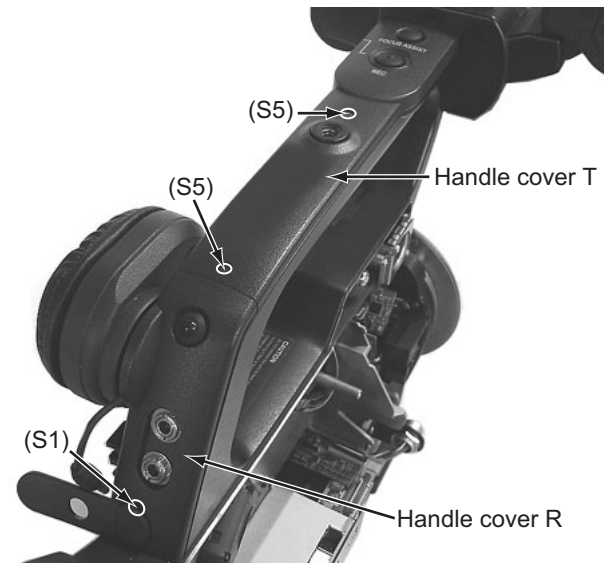

Fig.32

- (4) Disconnect the wire from the connector [CN48](#) on the EAR board.
- (5) Remove the three screws (**S4**) attaching the handle assembly.

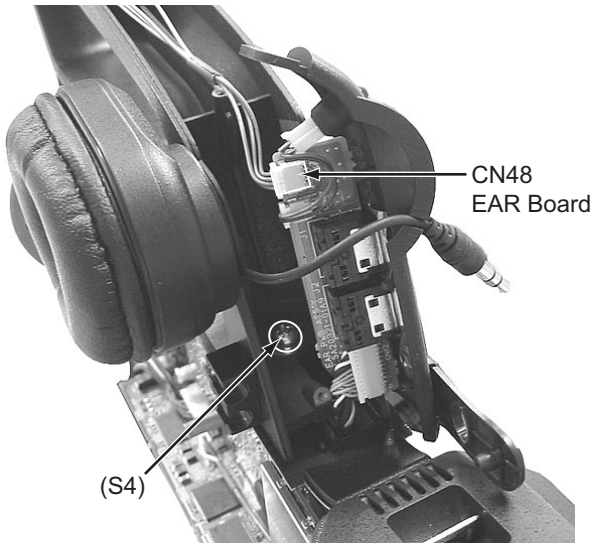

Fig.33

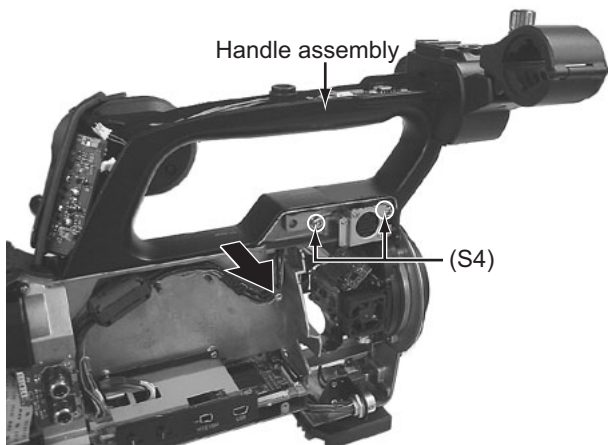

Fig.34

- (6) The handle assembly is easily removed by slightly sliding to the direction of the arrow.
 - When connecting the LED connector on EAR board, ensure the polarity that the red wire should be connected longer pin of the LED.

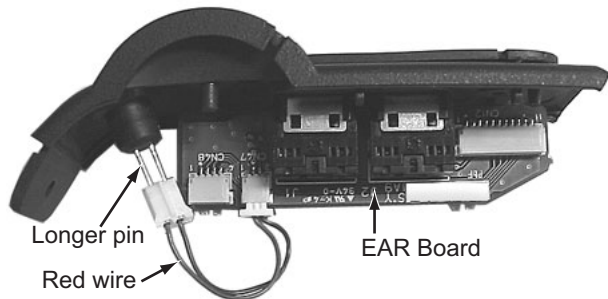

Fig.35

3.6 HOW TO REMOVE THE VIEW FINDER ASSEMBLY

3.6.1 Removing the lens unit assembly (See figure 36, figure 37 and figure 38)

- (1) Loosen the lock ring, then pull out the lens unit assembly.



Fig.36

- (2) Insert a fine screwdriver into the hole on the back of the slide cover. While keeping the fine screwdriver inserted, turn the lens unit assembly to the direction of the arrow. The lens unit assembly can be removed.

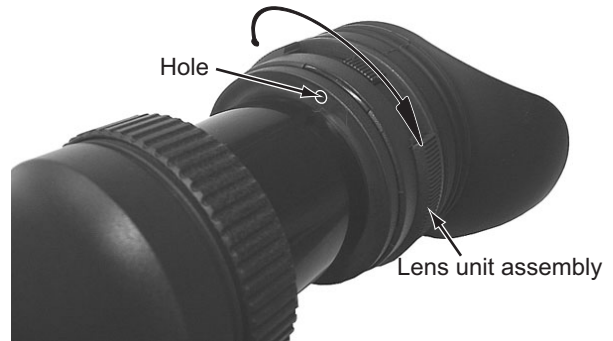

Fig.37

- (3) When attaching the lens unit assembly, align the marks on the slide cover and the lens unit assembly, then turn the lens unit assembly to the direction of the arrow to lock.



Fig.38

3.6.2 Removing the VF1 board and VF2 board (See figure 39, figure 40, figure 41, figure 42, figure 43 and figure 44)

- (1) Remove the lens unit assembly (Refer to the 3.6.1).
- (2) Remove the two screws (S1) attaching the VF case B.
- (3) Remove the lock ring.

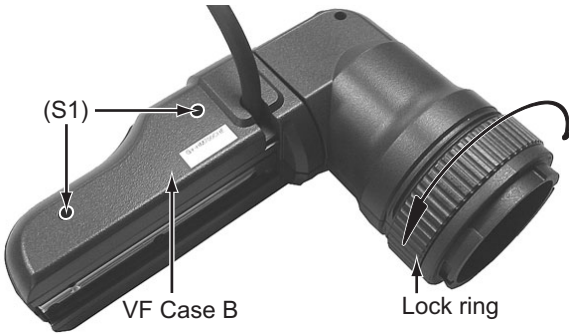

Fig.39

- (4) Remove the three screws C attaching the VF cover B.

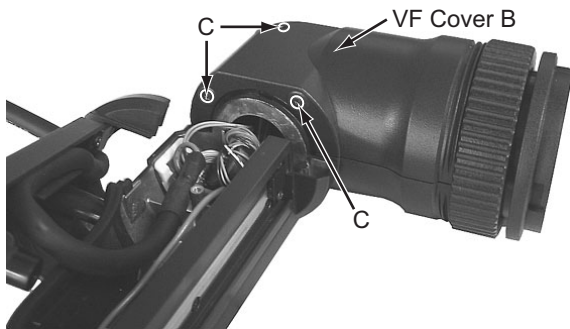
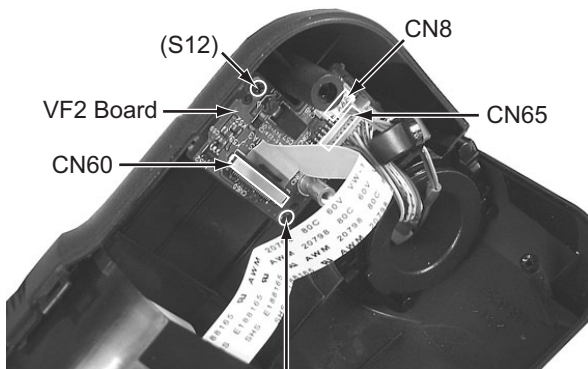

Fig.40

- (5) Disconnect the wires from the connectors CN8, CN60 and CN65 on the VF2 board.
- (6) Remove the two screws (S12) attaching the VF2 board, then remove the VF2 board.



(S12)
Fig.41

- (7) Remove the two screws D attaching the LCD module unit, then remove the LCD module unit.

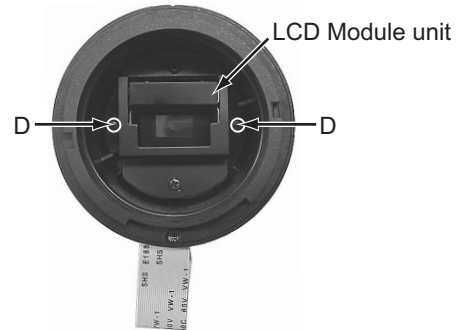

Fig.42

- To attach the LCD module unit, put the wire through the slit.

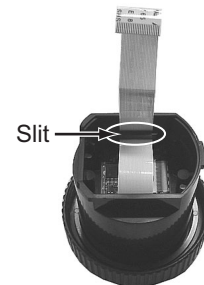

Fig.43

- (8) Disconnect the FPC from the connector CN61 on the VF1 board.
- (9) Remove the two screws (S12) attaching the VF1 board, then remove the VF1 board.

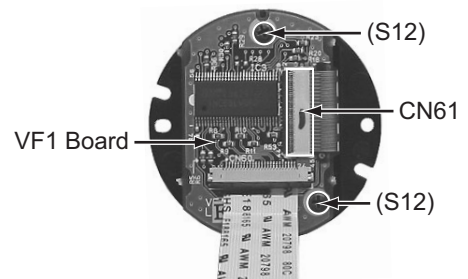

Fig.44



SECTION 4 ADJUSTMENT

4.1 FUNCTIONS REQUIRED FOR ADJUSTMENTS, SETUP

4.1.1 General instruments necessary for adjustment

Instrument	Condition	Instrument	Condition
Oscilloscope	Calibrated instrument with a measuring bandwidth of 100 MHz or more.	Frequency counter	Instrument calibrated for 8 digits or more. Stability of 0.1 ppm or 1×10^{-7} or better is required at 0 to 40 °C.
Vectorscope	Calibrated instrument	Monitor TV	Color video monitor with a 75Ω video input.
Audio tester	Calibrated instrument		

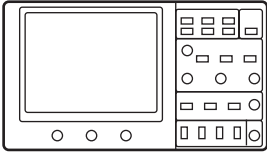
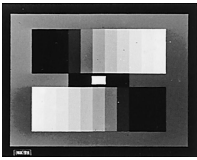
4.1.2 Special implements required for adjustment

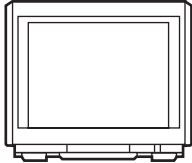
1	Waveform monitor (WFM)	2	Gray scale chart (HD/SD)	3	Tripod base (KA-551U)	4	Monitor TV (SD/HD)
		(Part No. : RESC-017 [for HD]) (Part No. : GS2L [for SD]) 					

4.2 STANDARD SETUP

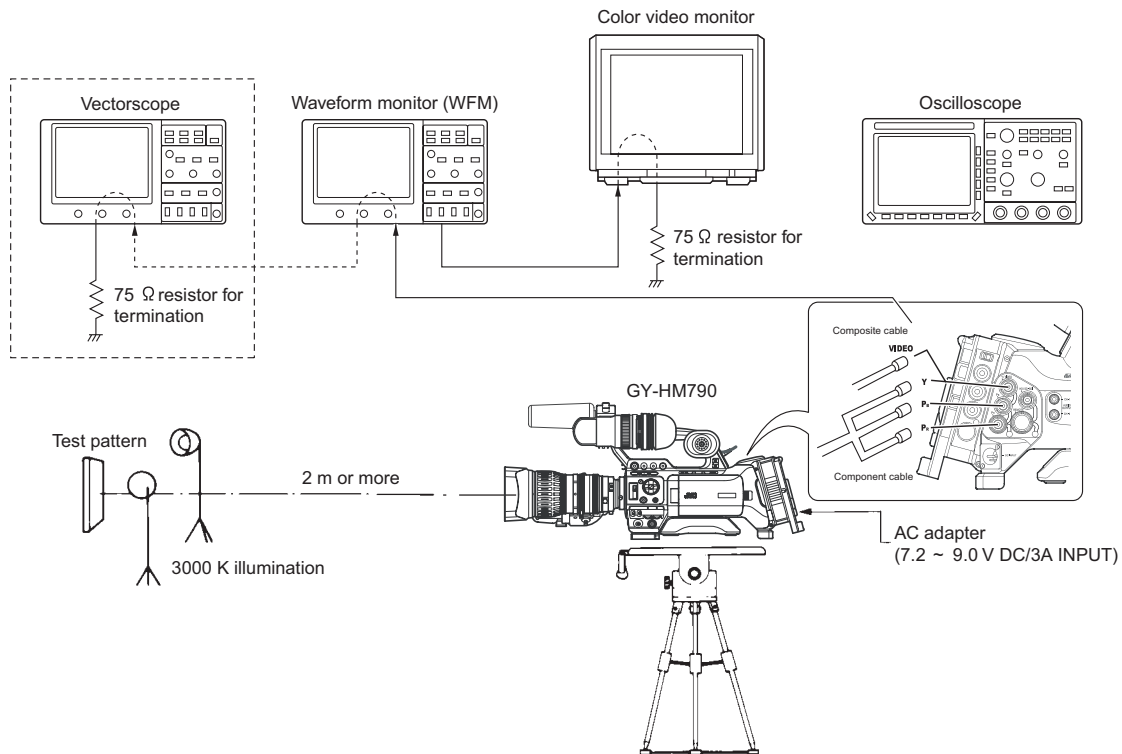

4.3 ADJUSTMENT MENU

4.3.1 Adjustment items

■ : The items shown in gray screen below that they do not require the adjustment as the factory use only.

Tops : To jump the menu items shown with bold items, press and hold the USER-3 button, and press USER-1 or USER-2 together at the same time.

Adj No.	Adjustment item	Adjustment range	Mode	Display order
0	MODE SELECT	790U, 790E, 790I, 790EC	60, 50, 48, 40	1
1	VIDEO MODE CHANGE	60, 50, 40, 48, OTHER	60, 50, 48, 40	2
2	27MHz CAM	0 to 255	60	3
3	CPS Y GAIN	0 to 255	60	4
4	CPN Y GAIN	0 to 255	60	5
25	IN GAIN[G]	-128 to 127	60, 50, 48, 40	6
26	IN GAIN[B]	-128 to 127	60, 50, 48, 40	7
27	IN GAIN[R]	-128 to 127	60, 50, 48, 40	8
28	WHITE OFFSET[G]	-128 to 127	60, 50, 48, 40	9
29	WHITE OFFSET[B]	-128 to 127	60, 50, 48, 40	10
30	WHITE OFFSET[R]	-128 to 127	60, 50, 48, 40	11
31	BLACK[G]L	-128 to 127	60, 50, 48, 40	12
32	BLACK[G]R	-128 to 127	60, 50, 48, 40	13
33	BLACK[B]L	-128 to 127	60, 50, 48, 40	14
34	BLACK[B]R	-128 to 127	60, 50, 48, 40	15
35	BLACK[R]L	-128 to 127	60, 50, 48, 40	16
36	BLACK[R]R	-128 to 127	60, 50, 48, 40	17
300	LINEARITY ALL RESET (*1)	-	60, 50, 48, 40	18
350	CAM LINEARITY	-	60, 50, 48, 40	19
352	AFE TEST LINEARITY	-	60, 50, 48, 40	20
450	LINT FINE 2112[G]R	-5 to 5	60, 50, 48, 40	21
451	LINT FINE 2112[B]R	-5 to 5	60, 50, 48, 40	22
452	LINT FINE 2112[R]R	-5 to 5	60, 50, 48, 40	23
453	LINT FINE 2176[G]R	-5 to 5	60, 50, 48, 40	24
454	LINT FINE 2176[B]R	-5 to 5	60, 50, 48, 40	25
455	LINT FINE 2176[R]R	-5 to 5	60, 50, 48, 40	26
456	LINT FINE 2304[G]R	-5 to 5	60, 50, 48, 40	27
457	LINT FINE 2304[B]R	-5 to 5	60, 50, 48, 40	28
458	LINT FINE 2304[R]R	-5 to 5	60, 50, 48, 40	29
459	LINT FINE 2432[G]R	-5 to 5	60, 50, 48, 40	30
460	LINT FINE 2432[B]R	-5 to 5	60, 50, 48, 40	31
461	LINT FINE 2432[R]R	-5 to 5	60, 50, 48, 40	32
462	LINT FINE 2560[G]R	-5 to 5	60, 50, 48, 40	33
463	LINT FINE 2560[B]R	-5 to 5	60, 50, 48, 40	34
464	LINT FINE 2560[R]R	-5 to 5	60, 50, 48, 40	35
301	LIN.0TH X POSI[G]R	-	60, 50, 48, 40	36
302	LIN.0TH OFFSET[G]R	-	60, 50, 48, 40	37
303	LIN.1ST X POSI[G]R	-	60, 50, 48, 40	38
304	LIN.1ST OFFSET[G]R	-	60, 50, 48, 40	39
305	LIN.LAST OFFSET[G]R	-	60, 50, 48, 40	40
306	LIN.0TH X POSI[B]R	-	60, 50, 48, 40	41
307	LIN.0TH OFFSET[B]R	-	60, 50, 48, 40	42
308	LIN. 1ST X POSI[B]R	-	60, 50, 48, 40	43
309	LIN. 1ST OFFSET[B]R	-	60, 50, 48, 40	44
310	LIN.LAST OFFSET[B]R	-	60, 50, 48, 40	45
311	LIN.0TH X POSI[R]R	-	60, 50, 48, 40	46
312	LIN.0TH OFFSET[R]R	-	60, 50, 48, 40	47
313	LIN. 1ST X POSI[R]R	-	60, 50, 48, 40	48
314	LIN. 1ST OFFSET[R]R	-	60, 50, 48, 40	49
315	LIN.LAST OFFSET[R]R	-	60, 50, 48, 40	50
40	FLARE[B]	0 to 40	60, 50, 48, 40	51
41	FLARE[R]	0 to 40	60, 50, 48, 40	52
42	MASTER FLARE	0 to 20	60, 50, 48, 40	53
43	BLACK SHADING[G]L	-39 to 39	60, 50, 48, 40	54
44	BLACK SHADING[G]R	-39 to 39	60, 50, 48, 40	55

Adj No.	Adjustment item	Adjustment range	Mode	Display order
45	BLACK SHADING[B]L	-39 to 39	60, 50, 48, 40	56
46	BLACK SHADING[B]R	-39 to 39	60, 50, 48, 40	57
47	BLACK SHADING[R]L	-39 to 39	60, 50, 48, 40	58
48	BLACK SHADING[R]R	-39 to 39	60, 50, 48, 40	59
353	AUTO H SHADING	-	60, 50, 48, 40	60
412	HOB WSPOT3 [G]L	0 to 665	60	61
413	HOB WSPOT3 [G]R	0 to 665	60	62
414	HOB WSPOT3 [B]L	0 to 665	60	63
415	HOB WSPOT3 [B]R	0 to 665	60	64
416	HOB WSPOT3 [R]L	0 to 665	60	65
417	HOB WSPOT3 [R]R	0 to 665	60	66
420	VT WSPOT [B]L	0 to 639	60	67
421	VT WSPOT [B]R	0 to 639	60	68
422	VT WSPOT [R]L	0 to 639	60	69
423	VT WSPOT [R]R	0 to 639	60	70
7	LCD BACKLIGHT	73 to 231	60, 50, 48, 40	71
13	FS PLL 48kHz	0 to 255	60, 50, 48, 40	72
200	AFE ALL RESET	-	60, 50, 48, 40	73
201	H1 START[G]	0 to 63	60, 50, 48, 40	74
202	H1 STOP[G]	0 to 63	60, 50, 48, 40	75
203	H2 START[G]	0 to 63	60, 50, 48, 40	76
204	H2 STOP[G]	0 to 63	60, 50, 48, 40	77
205	H1L START[G]L	0 to 63	60, 50, 48, 40	78
206	H1L STOP[G]L	0 to 63	60, 50, 48, 40	79
207	RESET START[G]L	0 to 63	60, 50, 48, 40	80
208	RESET STOP[G]L	0 to 63	60, 50, 48, 40	81
209	SHP PHASE[G]L	0 to 63	60, 50, 48, 40	82
210	SHD PHASE[G]L	0 to 63	60, 50, 48, 40	83
211	AD OUT PHASE[G]L	0 to 31	60, 50, 48, 40	84
212	LVDS CLK[G]L	0 to 15	60, 50, 48, 40	85
424	AFE CLAMP[G]L	-128 to 127	60, 50, 48, 40	86
213	H1L START[G]R	0 to 63	60, 50, 48, 40	87
214	H1L STOP[G]R	0 to 63	60, 50, 48, 40	88
215	RESET START[G]R	0 to 63	60, 50, 48, 40	89
216	RESET STOP[G]R	0 to 63	60, 50, 48, 40	90
217	SHP PHASE[G]R	0 to 63	60, 50, 48, 40	91
218	SHD PHASE[G]R	0 to 63	60, 50, 48, 40	92
219	AD OUT PHASE[G]R	0 to 31	60, 50, 48, 40	93
220	LVDS CLK[G]R	0 to 15	60, 50, 48, 40	94
425	AFE CLAMP[G]R	-128 to 127	60, 50, 48, 40	95
351	AFE TEST MODE	128	60, 50, 48, 40	96
221	H1 START[B]	0 to 63	60, 50, 48, 40	97
222	H1 STOP[B]	0 to 63	60, 50, 48, 40	98
223	H2 START[B]	0 to 63	60, 50, 48, 40	99
224	H2 STOP[B]	0 to 63	60, 50, 48, 40	100
225	H1L START[B]L	0 to 63	60, 50, 48, 40	101
226	H1L STOP[B]L	0 to 63	60, 50, 48, 40	102
227	RESET START[B]L	0 to 63	60, 50, 48, 40	103
228	RESET STOP[B]L	0 to 63	60, 50, 48, 40	104
229	SHP PHASE[B]L	0 to 63	60, 50, 48, 40	105
230	SHD PHASE[B]L	0 to 63	60, 50, 48, 40	106
231	AD OUT PHASE[B]L	0 to 31	60, 50, 48, 40	107
232	LVDS CLK[B]L	0 to 15	60, 50, 48, 40	108
426	AFE CLAMP[B]L	-128 to 127	60, 50, 48, 40	109
233	H1L START[B]R	0 to 63	60, 50, 48, 40	110
234	H1L STOP[B]R	0 to 63	60, 50, 48, 40	111

Adj No.	Adjustment item	Adjustment range	Mode	Display order	Adj No.	Adjustment item	Adjustment range	Mode	Display order
235	RESET START[B]R	0 to 63	60, 50, 48, 40	112	249	SHP PHASE[R]L	0 to 63	60, 50, 48, 40	128
236	RESET STOP[B]R	0 to 63	60, 50, 48, 40	113	250	SHD PHASE[R]L	0 to 63	60, 50, 48, 40	129
237	SHP PHASE[B]R	0 to 63	60, 50, 48, 40	114	251	AD OUT PHASE[R]L	0 to 31	60, 50, 48, 40	130
238	SHD PHASE[B]R	0 to 63	60, 50, 48, 40	115	252	LVDS CLK[R]L	0 to 15	60, 50, 48, 40	131
239	AD OUT PHASE[B]R	0 to 31	60, 50, 48, 40	116	428	AFE CLAMP[R]L	-128 to 127	60, 50, 48, 40	132
240	LVDS CLK[B]R	0 to 15	60, 50, 48, 40	117	253	H1L START[R]R	0 to 63	60, 50, 48, 40	133
427	AFE CLAMP[B]R	-128 to 127	60, 50, 48, 40	118	254	H1L STOP[R]R	0 to 63	60, 50, 48, 40	134
351	AFE TEST MODE	128	60, 50, 48, 40	119	255	RESET START[R]R	0 to 63	60, 50, 48, 40	135
241	H1 START[R]	0 to 63	60, 50, 48, 40	120	256	RESET STOP[R]R	0 to 63	60, 50, 48, 40	136
242	H1 STOP[R]	0 to 63	60, 50, 48, 40	121	257	SHP PHASE[R]R	0 to 63	60, 50, 48, 40	137
243	H2 START[R]	0 to 63	60, 50, 48, 40	122	258	SHD PHASE[R]R	0 to 63	60, 50, 48, 40	138
244	H2 STOP[R]	0 to 63	60, 50, 48, 40	123	259	AD OUT PHASE[R]R	0 to 31	60, 50, 48, 40	139
245	H1L START[R]L	0 to 63	60, 50, 48, 40	124	260	LVDS CLK[R]R	0 to 15	60, 50, 48, 40	140
246	H1L STOP[R]L	0 to 63	60, 50, 48, 40	125	429	AFE CLAMP[R]R	-128 to 127	60, 50, 48, 40	141
247	RESET START[R]L	0 to 63	60, 50, 48, 40	126	351	AFE TEST	-	60, 50, 48, 40	142
248	RESET STOP[R]L	0 to 63	60, 50, 48, 40	127	201	EFP COPY SYS TO CAM	-	60, 50, 48, 40	143

(*1) Do not push the set button because the data of SSE adjustment are reset. In this case, the replacement of the OP block is needed.

4.3.2 Switches and Functions Used in Adjustments

Most of the adjustment items employ microcomputer-controlled adjustments using electric potentiometers. The adjustment data is stored in EEPROM.

The switches used in the adjustments and their functions are as follows.

- [MENU] Button : Press to start from the adjustment menu.
- [USER 1], [USER 2] Button : Press to select the adjustment item.
- [Cross-Shaped] (UP/DOWN) Button : Press UP/DOWN to adjust the selected item.
- [Set] Button : Press to start an adjustment and store the adjustment value in memory.

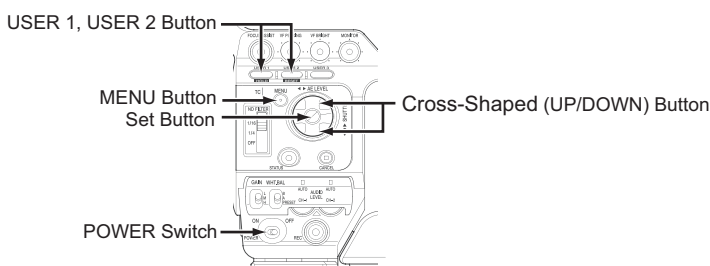

4.3.3 Procedure

- (1) Turn the power ON, while holding the [USER 1] and [USER 2] buttons.
- (2) When the power is ON, press the [MENU] button to display the ADJUST MENU.
- (3) Push the [Set] button so that "*" lighting, and the [Cross-Shaped] (UP/DOWN) button to the specified value while observing the designated TP and measuring instrument.

Note:
Do not turn the power off while "*" is blinking. Because all adjustment data may be broken.

- (4) After completing the adjustment, push the [Set] button to delete the "*" and store the adjustment value in memory.
- (5) Press the [USER 1] and [USER 2] button to select the next item to adjust.
- (6) Adjust for each item to do same procedure as above (3)(4).
- (7) After completing all adjustments, turn the power OFF and ON again.
- (8) To return to normal operation mode, turn the power OFF and ON again. (If did not re-start camera power, camera will be still in ADJUST MODE, so if press the [MENU] button then ADJUST MENU indicate on the screen and will not indicate normal menu screen.)

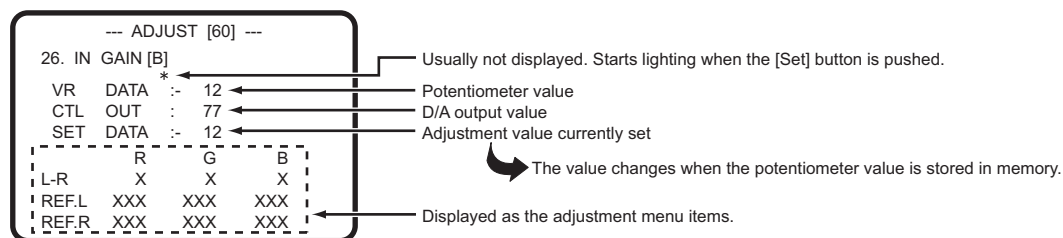

4.3.4 Adjustment mode

* When the adjustment item is selected, the input signal, internal mode and output signal flow are automatically set as specified.

4.4 FLOWCHART OF ADJUSTMENTS

NOTE :

As the camera adjustment data is stored in the EEP-ROM on the OP block, the split screen adjustments are complete at the factory before OP block assembly is supplied as service part.
 When replace the OP block assembly, only camera process adjustment is required. The SYS CPU has backup of the camera process adjustment data, so copy it from SYS to EEP-ROM on OP block by the service menu No. 201 when replace the OP block assembly.

In case of the split screen is visible

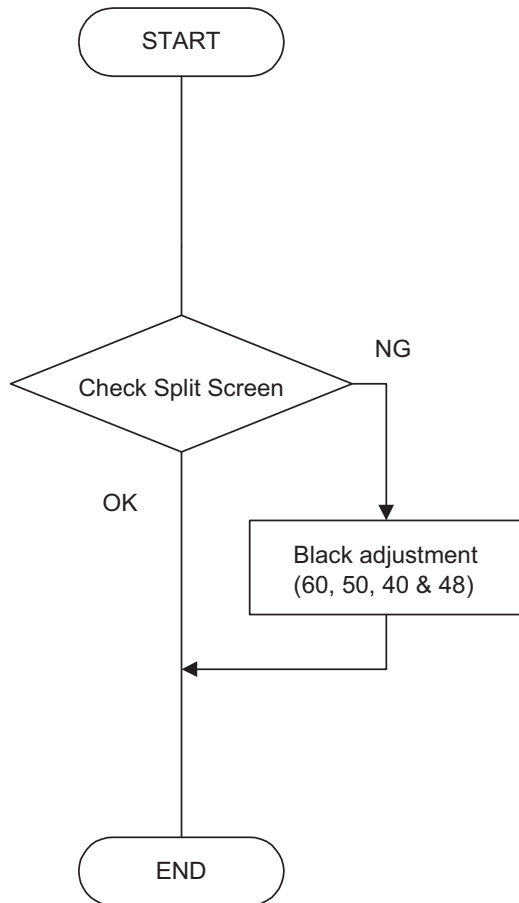

When the OP block assembly is replaced

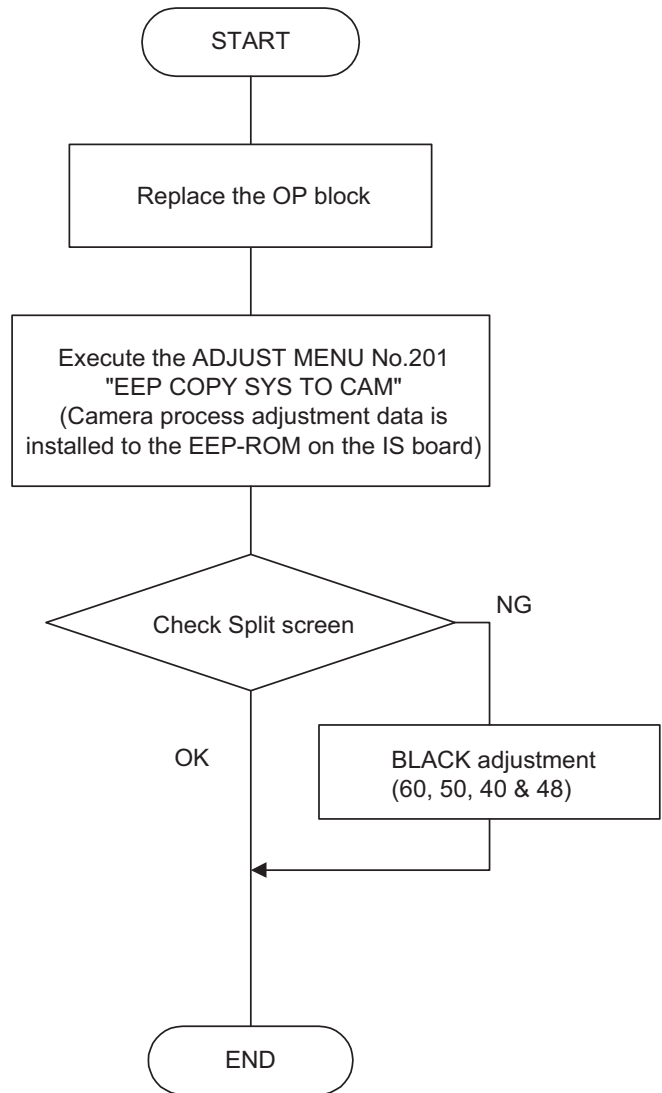

4.5 CAMERA ADJUSTMENTS

4.5.1 Encoder adjustment

Vectorscope settings as follows.

Saturation: 75%, SET UP: 7.5%

No.	Item	Measuring Instruments & Input Signals	Mode	Measuring Point (A) Adjustment Points (B) Adjustment Level (C)	Adjustment Procedure
1	Preparation		ADJUST MENU No.1 "VIDEO MODE CHANGE"	(C)60(NTSC)	(1) Select ADJUST MENU No.1, "VIDEO MODE CHANGE" (2) If system is not in [60](NTSC), select the "60"and press the [Set] button. (The camcoder will reboot automatically)
2	27MHz CAM adjustment	Frequency counter	ADJUST MENU No.2 "27MHZ CAM"	(A)Pb OUT (B)[Cross-Shaped] (UP/DOWN) button (C)27MHz \pm 30Hz	(1) Select ADJUST MENU No.2 "27MHZ CAM". (2) Push the [Set] button so that "*" lighting, and then push the [Cross-Shaped](UP/DOWN) button to adjust to the specified value. (3) Push the [Set] button to store the adjustment.
3	Composite Y level adjustment	Waveform monitor (Oscilloscope)	ADJUST MENU No.3 "CPS Y GAIN"	(A)Y/VIDEO OUT (75 Ω terminated) (B)[Cross-Shaped] (UP/DOWN) button (C)Y level 1.0Vp-p	(1) Select ADJUST MENU No.3 "CPS Y GAIN". (2) Push the [Set] button so that "*" lighting, and then push the [Cross-Shaped](UP/DOWN) button so that the Y level is as specified. (3) Push the [Set] button to store the adjustment.
4	Component Y level adjustment	Waveform monitor (Oscilloscope)	ADJUST MENU No.4 "CPN Y GAIN"	(A)Y/VIDEO OUT (75 Ω terminated) (B)[Cross-Shaped] (UP/DOWN) button (C)Y level 1.0Vp-p	(1) Select ADJUST MENU No.4 "CPN Y GAIN". (2) Push the [Set] button so that "*" lighting, and then push the [Cross-Shaped](UP/DOWN) button so that the Y level is as specified. (3) Push the [Set] button to store the adjustment.

4.5.2 Cam adjustment

No.	Item	Measuring Instruments & Input Signals	Mode	Measuring Point (A) Adjustment Points (B) Adjustment Level (C)	Adjustment Procedure
1	Preparation	<p>(1) Attach the Lens and Lens connector to the unit. (2) Setting of Switches ND FILTER : OFF GAIN : L WHT.BAL : A FULL AUTO : OFF (3) Select ADJUST MENU No.1 "VIDEO MODE CHANGE" and change the VIDEO MODE to [60](NTSC). (4) Shoot the Light Box and set the Zoom position to TELE end and fix the position so that there is no chading</p> <p>NOTE: This adjustment is after more than 15 minutes switched on the power of GY-HM790.</p>			
2	FLARE adjustment	-	ADJUST MENU No.40 "FLARE [B]"	(A)Y/VIDEO OUT (75Ω terminated) (B)[Cross-Shaped] (UP/DOWN) button (C)DATA:13	<p>Note: This adjustment is no required when replacing the OP block because this adjustment is adjusted in the factory.</p> <p>(1) Select ADJUST MENU No.40 "FLARE [B]". (2) Push the [Set] button so that "*" lighting, and then push the [Cross-Shaped](UP/DOWN) button to adjust to the specified value. (3) Push the [Set] button to store the adjustment data.</p> <p>(4) Select ADJUST MENU No.41 "FLARE [R]". (5) Push the [Set] button so that "*" lighting, and then push the [Cross-Shaped](UP/DOWN) button to adjust to the specified value. (6) Push the [Set] button to store the adjustment data.</p>
			ADJUST MENU No.41 "FLARE [R]"	(A)Y/VIDEO OUT (75Ω terminated) (B)[Cross-Shaped] (UP/DOWN) button (C)DATA:13	

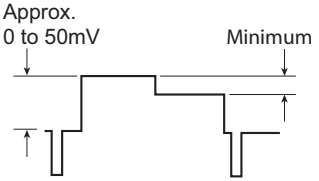
No.	Item	Measuring Instruments & Input Signals	Mode	Measuring Point (A) Adjustment Points (B) Adjustment Level (C)	Adjustment Procedure
3	Note: Before proceeding to perform the BLACK adjustment, be sure to warm up the OP Block for 15 minutes or more.				
	BLACK adjustment [60](NTSC)	Waveform monitor (Oscilloscope)	ADJUST MENU No.32 "BLACK [G] R" GAIN: 18dB	(A)Y/VIDEO OUT (75Ω terminated) (B)[Cross-Shaped] (UP/DOWN) button (C)Minimize the level difference between left and right side.	(1) Select ADJUST MENU No.32 "BLACK [G] R". (2) Shoot the White chart (light box), and set the Y level to 50mV. (3) Setting switches GAIN : H ND FILTER : 1/16 (4) Push the [Set] button so that "*" lighting. (5) Push the [Cross-Shaped](UP/DOWN) button so that the right side level should be same as the left side. (6) Push the [Set] button to store the adjustment data. (7) Select ADJUST MENU No.34 "BLACK [B] R".
			ADJUST MENU No.34 "BLACK [B] R" GAIN: 18dB	(A)Y/VIDEO OUT (75Ω terminated) (B)[Cross-Shaped] (UP/DOWN) button (C)Minimize the level difference between left and right side.	(8) Shoot the White chart (light box), and set the Y level to 50mV. (9) Push the [Set] button so that "*" lighting. (10) Push the [Cross-Shaped](UP/DOWN) button so that the right side level should be same as the left side. (11) Push the [Set] button to store the adjustment data. (12) Select ADJUST MENU No.36 "BLACK [R] R".
			ADJUST MENU No.36 "BLACK [R] R" GAIN: 18dB	(A)Y/VIDEO OUT (75Ω terminated) (B)[Cross-Shaped] (UP/DOWN) button (C)Minimize the level difference between left and right side.	(13) Shoot the White chart (light box), and set the Y level to 50mV. (14) Push the [Set] button so that "*" lighting. (15) Push the [Cross-Shaped](UP/DOWN) button so that the right side level should be same as the left side. (16) Push the [Set] button to store the adjustment data.
Note: When adjusting the Y level of the lens iris from 0mV to 200mV, confirm that the level difference between left and right are 5mV or less. If it is not, adjust the BLACK adjustment again.					
4	BLACK adjustment [50](PAL) [40] [48]	Waveform monitor (Oscilloscope)	ADJUST MENU No.32 "BLACK [G] R" ADJUST MENU No.34 "BLACK [B] R" ADJUST MENU No.36 "BLACK [R] R"	(A)Y/VIDEO OUT (75Ω terminated) (B)[Cross-Shaped] (UP/DOWN) button (C)Minimize the level difference between left and right side.	(1) Select ADJUST MENU No.1 "VIDEO MODE CHANGE" and Change the VIDEO MODE to [50](PAL). Perform black adjustment in the same way as [60](NTSC) (2) Select ADJUST MENU No.1 "VIDEO MODE CHANGE" and Change the VIDEO MODE to [40]. Perform black adjustment in the same way as [60](NTSC) (3) Select ADJUST MENU No.1 "VIDEO MODE CHANGE" and Change the VIDEO MODE to [48]. Perform black adjustment in the same way as [60](NTSC)

4.5.3 HOB/VT White blemish adjustment

NOTE:

This adjustment is only required when the white blemish correction is mis-clamping.

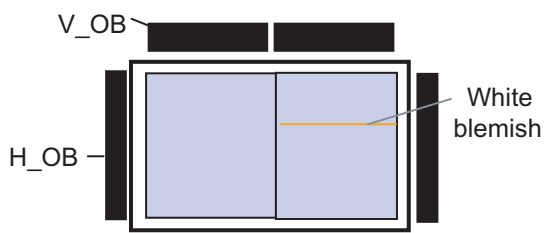
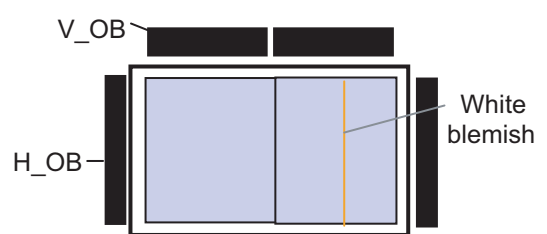
No.	Item	Measuring Instruments & Input Signals	Mode	Measuring Point (A) Adjustment Points (B) Adjustment Level (C)	Adjustment Procedure
1	HOB WHITE SPOT	HD MONITOR	ADJUST MENU No.412 No.413 No.414 No.415 No.416 No.417	(A)Y/VIDEO OUT (75Ω terminated) (B)[Cross-Shaped] (UP/DOWN) button (C)Disappear the strip noise	(1) When color strip noise caused by the horizontal OP blemish appears slightly on the monitor, execute the ADJUST MENU below to eliminate the color strip noise. No.412 "HOB WSPOT3 [G] L" No.413 "HOB WSPOT3 [G] R" No.414 "HOB WSPOT3 [B] L" No.415 "HOB WSPOT3 [B] R" No.416 "HOB WSPOT3 [R] L" No.417 "HOB WSPOT3 [R] R" (2) Check which side of the monitor and R/G/B the color noise occurs. (3) Select the corresponding adjust menu and push the [Set] button. The marker line appears on the monitor. (4) Move the marker line to the center of the color strip noise so that the color noise data.
					
2	VT WHITE SPOT	HD MONITOR	ADJUST MENU No.420 No.421 No.422 No.423	(A)Y/VIDEO OUT (75Ω terminated) (B)[Cross-Shaped] (UP/DOWN) button (C)Disappear the strip noise	(1) When the vertical white line caused by the vertical transfer blemish appears slightly on the monitor, execute the ADJUST MENU below to eliminate the white noise. No.420 "VT WSPOT [B] L" No.421 "VT WSPOT [B] R" No.422 "VT WSPOT [R] L" No.423 "VT WSPOT [R] R" (G-ch does not operate) (2) Check which side of the monitor and R/B the color noise occurs. (3) Select the corresponding adjust menu and push the [Set] button. The marker line appears on the monitor. (4) Move the marker line to the line noise so that the line noise disappears data.
					

SECTION 5 TROUBLE SHOOTING

5.1 SERVICE MENUS

5.1.1 Modes required in servicing

While holding down the specified button(s) (FOCUS ASSIST, USER 3), press the [MENU] button to display the first layer menu of the service menu hierarchy. The items in the first layer vary according to the specified button(s) being held when the [MENU] button is pressed. (Characters are displayed on LCD monitor screen or View finder.)

MENU Item	Displayed content	When power up		
		---	Holding [DISPLAY] button	
		Activation method		
		[FOCUS ASSIST] + [MENU]	[FOCUS ASSIST] + [USER 3] + [MENU]	
FIRMWARE	Firmware (Package) version indication	YES	N/A	N/A
VERSION CHECK	CPU and Program version indication	N/A	YES	N/A
ADVANCED FUNCTION	Camera settings, Blemish detect etc.	N/A	YES	YES
SERVICE FUNCTION	Test signal, Battery voltage settings etc.	N/A	N/A	YES
DIP SW	DIP SW Menu	N/A	N/A	YES
HOUR METER	Hour meter indication	N/A	N/A	YES
ERROR HISTORY	Error history indication	N/A	N/A	YES
OTHERS	All reset, Memory edit	N/A	N/A	YES

5.1.2 Operation in the first layer of the service menu

- (1) While holding down the specified button(s), press the [MENU] button.
- (2) The first layer of each service menu is displayed.
- (3) Press the [Cross-Shaped] buttons to move the cursor (▶) to the item to be displayed.
- (4) Press the [Set] button or the [Cross-Shaped] button (right) to select the item.

NOTE :

- During recording, the service menu does not start up.
- To go back to the upper layer, press the [CANCEL] button or the [Cross-Shaped] button (left).
- To cancel the service menu, press the [MENU] button.

5.1.2.1 VERSION MENU Display (Service menu 0)

- (1) Turn ON the power.
- (2) While holding down the [FOCUS ASSIST] button, press the [MENU] button to display the VERSION MENU.

Note:

The package version of the firmware is displayed in the VERSION MENU.
Select the VERSION CHECK menu in the ADVANCED MENU, when confirming the version of the CPU.

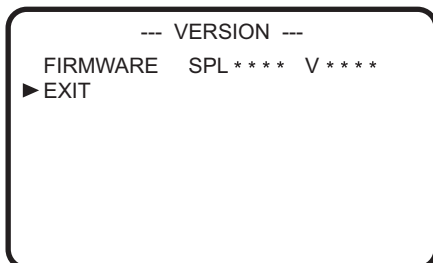

5.1.2.2 ADVANCED MENU Display (Service menu 1)

- (1) While holding down the [DISPLAY] button, turn ON the power.
- (2) While holding down the [FOCUS ASSIST] button, press the [MENU] button to display the ADVANCED MENU.

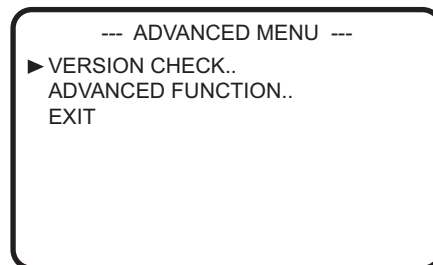

5.1.2.3 SERVICE MENU Display (Service menu 2)

- (1) While holding down the [DISPLAY] button, turn ON the power.
- (2) While holding down the [FOCUS ASSIST] button and the [USER 3] button, press the [MENU] button to display the SERVICE MENU.

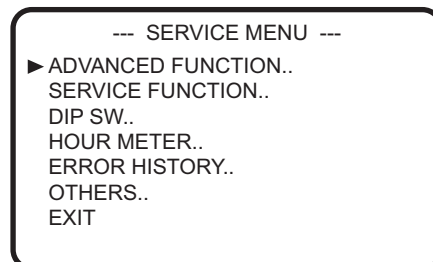

5.1.3 Firmware version display

- Refer to 5.1.2.1 to display the VERSION MENU.
- The program number and version of the firmware package are displayed.

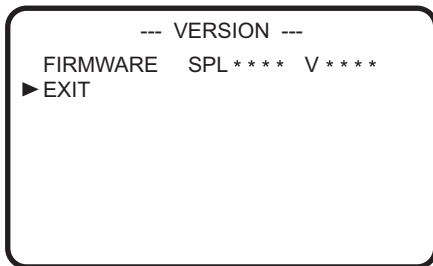

5.1.4 VERSION CHECK Display

- Refer to 5.1.2.2 to display the ADVANCED MENU.
- Move the cursor to [VERSION CHECK], then press the [Set] button or the [Cross-Shaped] button (right).
- The numbers and versions of each program are displayed.

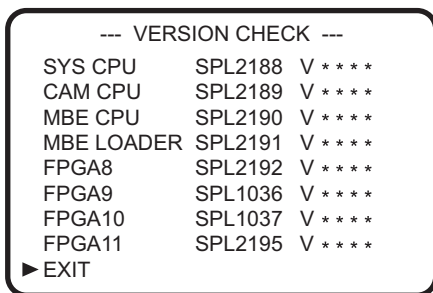

5.1.5 ADVANCED FUNCTION Menu operation

- Refer to 5.1.2.2 to display the ADVANCED MENU.
- Move the cursor to [ADVANCED FUNCTION], then press the [Set] button or the [Cross-Shaped] buttons (up/down) to change the parameter.
- ADVANCED FUNCTION Menu is displayed.
- Move the cursor to the item to be changed, then press the [Set] button or the [Cross-Shaped] button (right).
- The parameter blinks. Press the [Cross-Shaped] buttons (up/down) to change the parameter.
- Press the [Set] button to set the parameter. The parameter lights up.
- Move the cursor to [BACK], then press the [Set] button or the [Cross-Shaped] button (right) to go back to the upper layer and finish the setting.

NOTE :

- To cancel the parameter setting change, press the [CANCEL] button or the [Cross-Shaped] button (left) while the parameter is blinking.

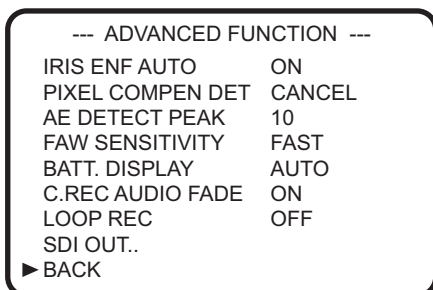

Item	Parameter	
IRIS ENF. AUTO	OFF	While in the FULL AUTO mode, the IRIS mode depends on the lens IRIS MODE switch setting.
	ON	While in the FULL AUTO mode, the Auto Iris mode is activated even the Manual Iris mode is selected.*1
PIXEL COMPEN DET *2	CANCEL	Does not execute blemish detection.
	EXECUTE	Executes blemish detection.
AE DETECT PEAK	10	Sets the VIDEO PEAK ratio for AE control. 0 to 50 (By 5%)
FAW SENSITIVITY	SLOW MIDDLE FAST	Sets the response speed of the FAW control.
BATT. DISPLAY	OFF	Does not display the battery information.
	AUTO	Follow the BATTERY INFO MENU setting.
C.REC AUDIO FADE*3	OFF	No AUDIO FADE in STBY↔REC.
	ON	AUDIO FADE in STBY↔REC.
LOOP REC	OFF	No LOOP REC.
	ON	Endless LOOP REC.
SDI OUT..		Refer to the 5.1.5.2

(Bold is the factory setting.)

*1 The lens iris is set to the auto mode by automatically at the followings.

- When the iris is operated by the RM controller.
- When the GAIN, the IRIS and the SHUTTER are setting to the auto mode.

*2 Available only when the Camera Resolution setting is 1280x720, and the Frame & Bit Rate setting is 60p(HQ) or 60p(SP). Otherwise, [---] is displayed and no selection is available.

*3 When only recording to the SDHC memory cord, this function is available.

5.1.5.1 White blemish detection

- Open the User Menu, then set [Camera Resolution] in [Record Format] to 1280x720, and [Frame & Bit Rate] to 60p(HQ) or 60p(SP).

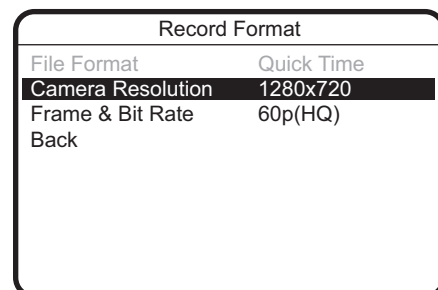

- Open the ADVANCED FUNCTION Menu, change the [PIXEL COMPEN DET] parameter to [EXECUTE], and then press the [Set] button.

- (3) [PIXEL COMPEN EXECUTING] is displayed and the detection required for white blemish correction automatically starts.
At this time, the camera lens is closed and the mode changes to the SLOW SHUTTER mode.

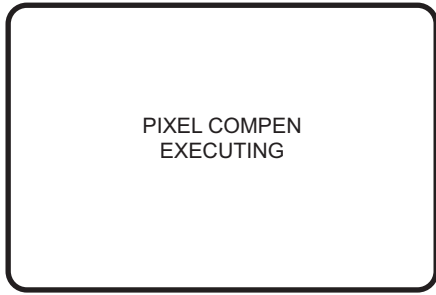

- (4) When the white blemish detection completes, the result data is stored in the CPU memory, and an end message is displayed as shown below. Turn OFF the power. (After completing white blemish detection, the "Camera Resolution" and "Frame & Bit Rate" settings return to the original settings.)

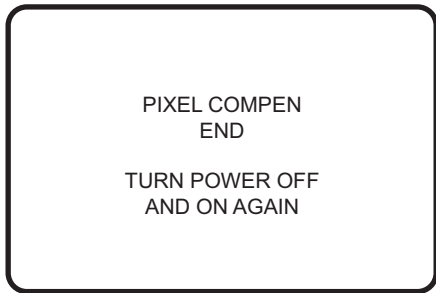

- (5) If any errors occur during the detection, an error message is displayed, then the screen returns to the MENU display.

Message	Error details	Operation
LENS NOT CLOSED?	The lens does not close for detection.	No result is stored in the EEPROM.
COUNT OVER	The number exceeds the specified count.	Only the specified count of data is stored in the EEPROM.

5.1.5.1.1 Details on correctable white blemish

Up to 127 errors with composite video levels of 50mV or more can be corrected. No limitation of errors per line within 127. However, the maximum consecutive errors are four and the correction results may be inferior to the single error correction. Oblique noise may be observed on the screen during the white blemish detection. This is due to the principles of error correction and is not a malfunction.

White blemish can be detected in the following area.

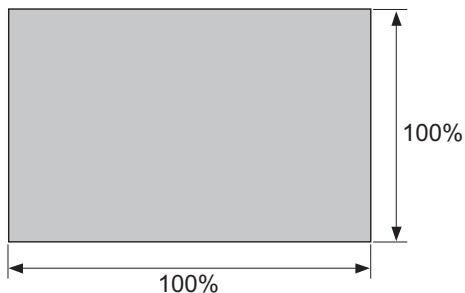

5.1.5.1.2 SDI OUT Menu operation

- Open the ADVANCED FUNCTION Menu, move the cursor to [SDI OUT], and then press the [Set] button or the [Cross-Shaped] button (right).
- The SDI OUT Menu is displayed.

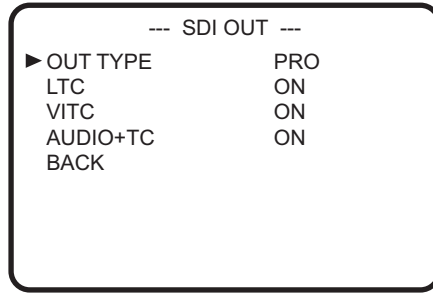

Refer to 5.1.5 ADVANCED FUNCTION Menu because the operations are almost the same.

Item	Parameter	
OUT TYPE	CONSUMER	Adds the AES/EBU consumer channel status bits.
	PRO	Adds the AES/EBU Professional channel status bits.
LTC	OFF	Does not add the LTC data on SDI output.
	ON	Adds the LTC data on SDI output.
VITC	OFF	Does not add the VITC data on SDI output.
	ON	Adds the VITC data on SDI output.
AUDIO+TC	OFF	Does not add the audio data and TC data on SDI output.
	ON	Adds the audio data and TC data on SDI output.

(Bold is the factory setting.)

5.1.6 SERVICE FUNCTION Menu Operation

- Refer to 5.1.2.3 to display the SERVICE MENU.
- Move the cursor to [SERVICE FUNCTION], then press the [Set] button or the [Cross-Shaped] button (right).
- The SERVICE FUNCTION Menu is displayed.

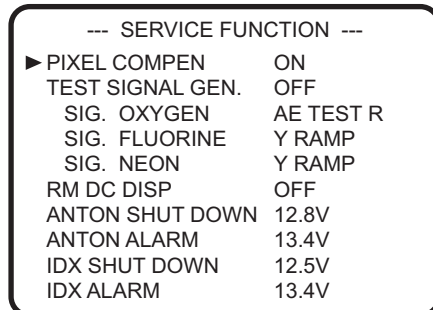

Refer to 5.1.5 ADVANCED FUNCTION Menu because the operations are almost the same.

Item	Parameter	
PIXEL COMPEN *1	OFF	Does not correct the detected white blemish.
	ON	Corrects the detected white blemish.
	CHECK	Light up the pixels which are the detected white blemish.
TEST SIGNAL	OFF	No output test signal.
	OXYGEN	Outputs OXYGEN (FPGA8) signal.
		AE TEST R , RAMP1, FRONT BAR, CENTER, AE TEST G, LR REVSE, RAMP+REF, VTRANS, AE TEST B, HS MARK, HOB MARK, REAR BAR
	FLUORINE	Outputs FLUORINE (FPGA9) signal.
		Y RAMP , C RAMP, SWEEP H, SWEEP V, 24PMOVING, TEST BAR, SECRET
	NEON	Outputs NEON (FPGA10) signal.
Y RAMP , C RAMP, SWEEP H, SWEEP V, TEST BAR, MOVING, FRAME		
RM DC DISP	OFF	When connected with RM-HP250, the voltage of power is not displayed.
	ON	When connected with RM-HP250, the voltage of power is displayed.
ANTON SHUT DOWN	12.0V	Setting of the ANTON battery voltage when shutdown should occur. Setting in 0.1V steps between 12.0V and 14.0V.
ANTON ALARM	12.8V	Setting of the ANTON battery voltage when the battery alarm indicated. Setting in 0.1V steps between 12.0V and 14.0V.
IDX SHUT DOWN	12.0V	Setting of the IDX battery voltage when shutdown should occur. Setting in 0.1V steps between 12.0V and 14.0V.
IDX ALARM	12.5V	Setting of the IDX battery voltage when the battery alarm indicated. Setting in 0.1V steps between 12.0V and 14.0V.

(Bold is the factory setting.)

*1 This mode is automatically set to ON when the power is turned ON.

The OFF mode is enabled only after it is set to OFF on this screen until the power is turned OFF.

5.1.7 DIP SW Menu Operation

- (1) Refer to 5.1.2.3 to display the SERVICE MENU.
- (2) Move the cursor to [DIP SW], then press the [Set] button or the [Cross-Shaped] button (right).
- (3) The DIP SW MAIN Menu is displayed.

```

--- DIP SW MAIN ---
▶ DIPSW ALL RESET CANCEL
DIP SW 0-7..
DIP SW 8-15..
DIP SW 16-23..
DIP SW 24-31..
DIP SW 32-39..
DIP SW 40-47..
DIP SW 48-55..
DIP SW 56-63..
BACK

```

```

--- DIP SW 1/8 ---
▶ DIP SW 0 0
DIP SW 1 OFF
DIP SW 2 OFF
DIP SW 3 OFF
DIP SW 4 OFF
DIP SW 5 OFF
DIP SW 6 OFF
DIP SW 7 OFF
BACK

```

```

--- DIP SW 2/8 ---
▶ DIP SW 8 OFF
DIP SW 9 OFF
DIP SW 10 OFF
DIP SW 11 OFF
DIP SW 12 OFF
DIP SW 13 OFF
DIP SW 14 OFF
DIP SW 15 OFF
BACK

```

```

--- DIP SW 3/8 ---
▶ DIP SW 16 OFF
DIP SW 17 OFF
DIP SW 18 OFF
DIP SW 19 0
DIP SW 20 OFF
DIP SW 21 0
DIP SW 22 OFF
DIP SW 23 OFF
BACK

```

```

--- DIP SW 4/8 ---
▶ DIP SW 24 0
DIP SW 25 OFF
DIP SW 26 OFF
DIP SW 27 OFF
DIP SW 28 OFF
DIP SW 29 OFF
DIP SW 30 OFF
DIP SW 31 0
BACK

```

```

--- DIP SW 5/8 ---
▶ DIP SW 32 OFF
DIP SW 33 OFF
DIP SW 34 OFF
DIP SW 35 OFF
DIP SW 36 OFF
DIP SW 37 OFF
DIP SW 38 OFF
DIP SW 39 OFF
BACK

```

```

--- DIP SW 6/8 ---
▶ DIP SW 40 OFF
DIP SW 41 OFF
DIP SW 42 OFF
DIP SW 43 OFF
DIP SW 44 OFF
DIP SW 45 OFF
DIP SW 46 OFF
DIP SW 47 OFF
BACK

```

```

--- DIP SW 7/8 ---
▶ DIP SW 48 OFF
DIP SW 49 OFF
DIP SW 50 OFF
DIP SW 51 OFF
DIP SW 52 OFF
DIP SW 53 OFF
DIP SW 54 OFF
DIP SW 55 OFF
BACK

```

```

--- DIP SW 8/8 ---
▶ DIP SW 56 0
DIP SW 57 0
DIP SW 58 0
DIP SW 59 0
DIP SW 60 0
DIP SW 61 0
DIP SW 62 0
DIP SW 63 0
BACK

```

Refer to 5.1.5 ADVANCED FUNCTION Menu because the operations are almost the same.

NOTE :
 ALL DIP switches are factory use only.
 These DIP switches are not used for repair or maintenance.
 Therefore all DIP Switch settings which are shown below should not be changed. And do not forget to return to the initial position, if setting was changed.

Item	Parameter		
DIP SW ALL RE-SET	CANCEL	Cancel to reset all DIPSW settings.	
	EXECUTE	Execute to reset all DIPSW settings.	
DIP SW 1/8	DIP SW 0	0	Change prohibited.
	DIP SW 1 to 7	OFF	Change prohibited.
DIP SW 2/8	DIP SW 8 to 15	OFF	Change prohibited.

Item	Parameter		
DIP SW 3/8	DIP SW 16 to 18	OFF	Change prohibited.
	DIP SW 19 and 21	0	
	DIP SW 20	OFF	
	DIP SW 22 and 23	OFF	
DIP SW 4/8	DIP SW 24 and 31	0	Change prohibited.
	DIP SW 25 to 30	OFF	
DIP SW 5/8	DIP SW 32 to 39	OFF	Change prohibited.
DIP SW 6/8	DIP SW 40 to 47	OFF	Change prohibited.
DIP SW 7/8	DIP SW 48 to 55	OFF	Change prohibited.
DIP SW 8/8	DIP SW 56 to 63	0	Change prohibited.

(Bold is the factory setting.)

5.1.8 HOUR METER Menu Operation

- Refer to 5.1.2.3 to display the SERVICE MENU.
- Move the cursor to [HOUR METER], then press the [Set] button or the [Cross-Shaped] button (right).
- The HOUR METER Menu is displayed.

```

--- HOUR METER ---
▶ POWER          000000H
FAN              000000H
SLOT EJECT      [A] 000000
                 [B] 000000
BACK

```

Refer to 5.1.5 ADVANCED FUNCTION Menu because the operations are almost the same.

Item	Parameter	
POWER	000000	Displays the power hour meter.
	CLEAR	Resets the power hour meter.
FAN	000000	Displays the fan hour meter.
	CLEAR	Resets the fan hour meter.
SLOT EJECT	000000	Displays the slot A and B eject count.
	CLEAR	Resets the slot A and B eject count.

5.1.9 ERROR HISTORY Menu Operation

NOTE :
 This menu is not used.

- Refer to 5.1.2.3 to display the SERVICE MENU.
- Move the cursor to [ERROR HISTORY], then press the [Set] button or the [Cross-Shaped] button (right).
- The ERROR HISTORY Menu is displayed.

```

--- ERROR HISTORY ---
▶ CLEAR          CANCEL
BACK

```

5.1.10 OTHERS Menu Operation

- (1) Refer to 5.1.2.3 to display the SERVICE MENU.
- (2) Move the cursor to [OTHERS], then press the [Set] button or the [Cross-Shaped] button (right).
- (3) The OTHERS Menu is displayed.

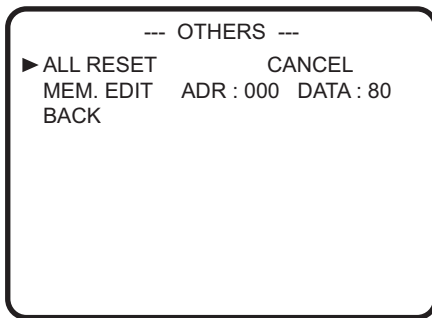

Refer to 5.1.5 ADVANCED FUNCTION Menu because the operations are almost the same.

Item	Parameter	
ALL RESET	CANCEL	Standard setting.
	EXECUTE	Resets all EEP-ROM data to default settings except adjustment data, hour meter data, and IEEE1394 ID data.
MEM.EDIT	Contents of the EEP-ROM can be edited directly. * ADR: Address (0x000-0x9DF) display * DATA: Display of data embedded in address shown by ADR Operation procedure (1) Move the cursor to [MEM.EDIT], then press the [Set] button or the [Cross-Shaped] button (right). (2) The ADR parameter blinks. Select the address (ADR) to be edited, then press the [Set] button or the [Cross-Shaped] button (right). (3) The DATA parameter blinks. Change the data. (4) Press the [Set] button or the [Cross-Shaped] button (right) to set the parameter. The parameter lights up. (5) Move the cursor to [BACK], then press the [Set] button or the [Cross-Shaped] button (right) to go back to the upper layer and finish the setting. NOTE: Data that is crucial for the system is stored in the EEP-ROM, and making unadvised changes to it can cause the unit to stop operating correctly. Please do not use anything other than the IEEE1394 ID setting.	

5.2 EEP-ROM

5.2.1 EEP-ROM and maintenance data

GY-HM790 is equipped with four EEP-ROMS for the purpose of data maintenance, and their contents are as per the following list. When the circuit board or EEP-ROM is replaced, there will be no data in the EEP-ROM. When the unit is turned ON, and the SYSCON CPU recognizes that there is no data in the EEP-ROM, it automatically writes initial data into the EEP-ROM to initialize it. The memory data shown in the table below will all be reset to the default settings. It is necessary to perform necessary adjustments and settings again.

EEP-ROM	Board name	Memory data content
IC10	ISB board (Camera CPU)	<ul style="list-style-type: none"> • Blemish data • Adjusted data (Camera section)
IC1504	CODEC board (SYSCON CPU)	<ul style="list-style-type: none"> • User menu and Service menu settings data • Adjustment data • IEEE1394 ID data • HOUR METER data

5.2.2 IEEE1394 ID setting method

IEEE1394 equipped units have an ID, as defined by the IEEE1394 standard, stored in the internal EEP-ROM (IC1504). At the time of production, the ID numbers allotted to each individual unit are written into the unit's memory, and a label bearing the ID is affixed inside the unit. When the EEP-ROM or MAIN circuit board is replaced, the ID needs to be set again.

(1) Procedure for setting IEEE1394 ID

The ID is an 8-digit hexadecimal code with 1 high-end Byte being the model code, and 3 low-end Bytes being unique to the unit. The model code is automatically initialized, so only the lower 3 Bytes of unique code need to be set manually.

Start from [SERVICE MENU] → [OTHERS] Menu → [MEM. EDIT] (Memory Edit) to select the address in the ID data section and make the setting directly.

The 3 low-end Byte address is as follows. Make the setting while checking the ID printed on the label (ID: 85xxxxxx) affixed inside the GY-HM790.

IEEE1394 ID data : 87 x x x x x x
 ↓ ↓ ↓

MEMORY Address number : "39C" "39D" "39E" (Each 1 Byte ID data are stored for every one memory address number.)

(2) Setting procedure

- a) Move the cursor to [MEM.EDIT], then press the [Set] button or the [Cross-Shaped] button (right).
- b) The ADR parameter blinks. Select [39C], then press the [Set] button or the [Cross-Shaped] button (right).
- c) The DATA parameter blinks. Set the ID written on the label.
- d) Press the [Set] button or the [Cross-Shaped] button (right) to set the parameter. The parameter lights up.
- e) Follow the same procedure above to set IDs for ADR parameters [39D] and [39E].
- f) Move the cursor to [BACK], then press the [Set] button or the [Cross-Shaped] button (right) to go back to the upper layer and finish the setting.

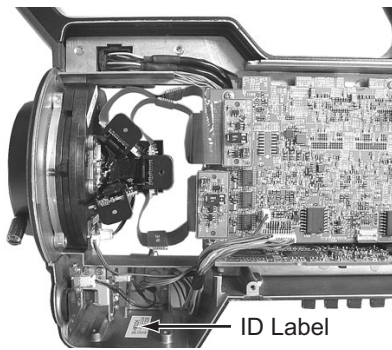

5.3 HOW TO UPDATE THE FIRMWARE

NOTE:

- When replacing CAM board or CODEC board, the firmware update is required to maintain combination with other CPU versions.
- Do not turn OFF the power during the update, Otherwise the CPU may be destroyed and replacement of IC or board may be required.
- Use an AC adapter for updating. Do not use a battery for firmware update.
- When the update is failed, audio AUTO LED's are flash alternately. In this case, remove the SD memory card, then try the update again.
- Remove the IEEE1394 cable, or it may cause troubles on the GY-HM790.
- Do not format the SD memory card by PC.
The SD memory card formatted on the PC may not work correctly. Format the SD memory card on the GY-HM790 if formatting is required.
- You can also use the SD memory cards formatted with digital still cameras, or formatted using formatting software supplied from SD memory card manufacturer such as Panasonic.

5.3.1 Preparation (Copy the firmware to SD memory card)

NOTE:

- The update file is named as "GY-HM790.UPD".
- The update file should be put on the directory "//PRIVATE/JVC/GY-HM790", otherwise the update is not executed.

- (1) Download the update file from JS-NET SMIS and unzip it to a PC.
- (2) Insert the SD memory card to the PC and confirm that no file is in the SD memory card. If there are some files, delete them.
- (3) Make the directory "//PRIVATE/JVC/GY-HM790" on the SD memory card.
- (4) Copy the unzipped update file to the folder "GY-HM790" on the SD memory card.

5.3.2 Update procedure

(1) While pressing the [MENU] and [FOCUS ASSIST(side)] buttons, turn ON the power. The VERSION menu is displayed immediately, after the UPGRADE READY was displayed.

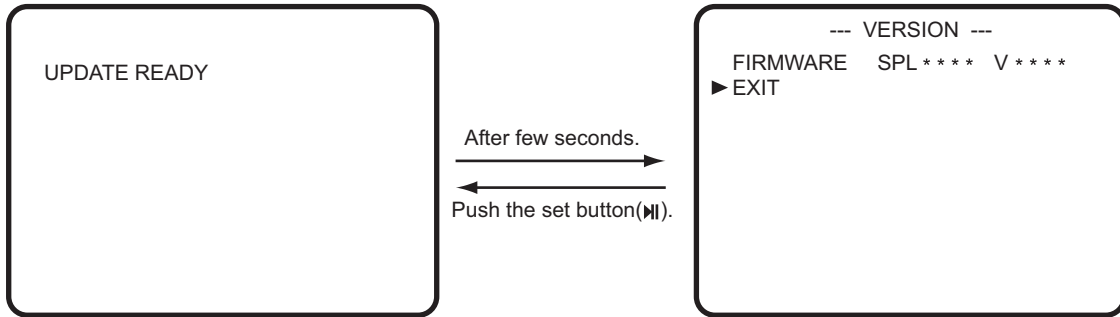

(2) Insert the SD memory card into the card slot B.

Note:
Can not be updated with slot A.

(3) The updating is started automatically, after the SD memory card was inserted. Progress bar is displayed on the LCD display while updating. The AUDIO AUTO LED of CH1 blink slowly and AUTO LED of CH2 is turned off.

LCD display

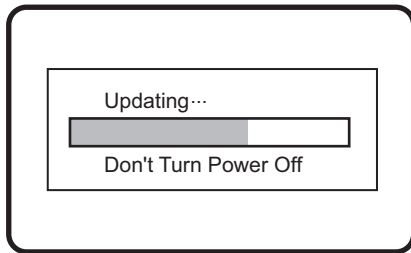

(4) When the update is completed, audio AUTO LEDs of AUDIO CH-1 and CH-2 blink slowly. It takes about 5 minutes to complete the update. Complete is displayed on the LCD display.

LCD display

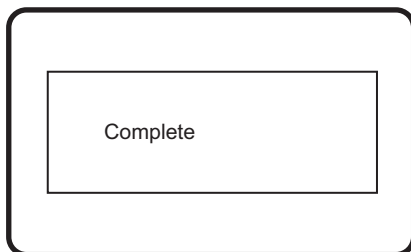

(5) After complete the updating, remove the SD memory card. The GY-HM790 reboots automatically.
 (6) Turn OFF the power and turn it ON again.
 (7) Enter the Service Menu to check the CPU VERSION.

Note :

Confirm the firmware in the SD card if the "update can't be Executed !" was displayed on the LCD display. (The AUTO LEDs of AUDIO CH1 and CH2 blink alternately, when update can not be executed.)

LCD display

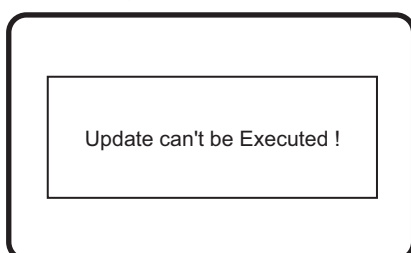

Check the defect of board or the connection of each board, if the "update error !" was displayed.

LCD display

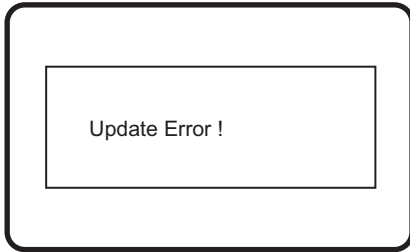

5.4 PRECAUTIONS WHEN CHANGING BOARDS

After changing the board in service, firmware version update and adjustment may be required.

5.4.1 When version update is required

For GY-HM790, there are multiple CPUs and FPGAs allocated on the two boards. (Refer to the table below)

CPU/FPGA has its own firmware and each firmware has its combination.

When the CAM board assembly or the CODEC board assembly is replaced, the combination of versions may not match. In such case, as camera could malfunction, make sure to perform version update after changing these boards.

Board assembly	CPU/FPGA with firmware
CAM Board assembly	IC37 (CAM CPU) IC8 (Flash ROM for FPGA9) IC12 (Flash ROM for FPGA8 and FPGA10)
CODEC Board assembly	IC1503 (SYS CPU) IC3 (Flash ROM for FPGA11) IC1006 (Flash ROM for MBE CPU)

5.4.2 When adjustment is required

The adjustment data is stored in the EEP-ROM.

When the board to be changed is mounted with EEP-ROM, readjustment is required as the adjustment data will be lost.

Boards mounted with EEP-ROM are ISB Board (OP Block) and CODEC board. (Refer to section 5.2 EEP-ROM.)

5.4.2.1 OPTICAL BLOCK ASSEMBLY (ISB BOARD)

The EEP-ROM (IC10) of camera CPU, which stores CCD adjustment data and camera process data, is mounted in OPTICAL BLOCK ASSEMBLY ISB Board.

OPTICAL BLOCK ASSEMBLY is supplied from the parts center after adjustment of CCD (Split Screen, Flare ADJ etc.) is completed.

By transferring the adjustment data of camera process after changing OP BLOCK ASSEMBLY, it is not required to readjust basically.

When the split screen appear on the monitor TV, confirm the 4.5.2 No.3 BLACK adjustment.

[How to transfer the adjustment data of camera process]

(1) Select the adjustment menu [201. EEP COPY SYS TO CAM] in the NTSC mode. (Refer to section 4.3 ADJUSTMENT MENU.)

(2) Press the [Set] button to start copying. The GY-HM790 reboots automatically. and the ADJUSTMENT MENU is displayed.

(3) Change the VIDEO MODE from NTSC to PAL, then execute the steps (1) to (2) in the same way.

NOTE :

The SYS CPU has the backup adjustment data of camera, and it's data is copied.

5.4.2.2 CODEC board Assembly

The adjustment data is stored in EEP-ROM IC1504. Adjustment is required after changing board.

NOTE :

To continue using the EEP-ROM data, it is also possible to remount original IC1504 onto the new board.



Victor Company of Japan, Limited
Business Solution Division

(No.HC034<Rev.001>)

Printed in Japan
VSE